

Engine Model: RM55, RM55ES  
RM60  
RM65, RM65ES



---

# SELF-HELP PROBLEM SOLVING and MAINTENANCE for PETROL LAWNMOWERS

The RM55, RM55ES, RM60, RM65 or RM65ES engine is fitted to the following products:

- 463 PD/ES
- M43 PD
- 483 R
- 553 R/ES
- SP536
- 463R PD/ES
- M63 PD
- 483 R/ES
- SP554
- SP536ES
- 513 PD/ES
- M63 PD/ES
- 553 R
- SP534ES

1. Safety Regulations .....	2
2. Fuel, Oil, Air Filter and Spark Plug Requirements.	3
3. Routine Engine Maintenance .....	4
4. Starting the Engine .....	7
5. Engine Starts and Smokes Heavily .....	12
6. Engine Cutting Out or Running Unevenly .....	14
7. Pull Cord Not Pulling or Snatching Back .....	15
8. Cutting and Collecting Grass, Vibration .....	17
9. Transportation and Handling .....	20
10. Maintenance and Storage .....	21
11. Guarantee, Spare Parts, Repairs .....	22

**If, after reading this guide, you feel you are either unsure of what is required, or that you do not have the correct tools to undertake a job yourself, please contact:**

- **Our Helpline service, telephone 0845 600 2912 (Monday to Saturday 9am – 5pm, and Sunday 10am – 4pm), or**
- **Our local Service Link centre who can undertake any remedial work requested (work that is not covered by the guarantee will be chargeable)**



**Your local Service Link centre can be found by contacting the Helpline and quoting the model of mower you have and your postcode. Alternatively, go to [www.servicelink.org.uk](http://www.servicelink.org.uk)**

**Engine Model: RM55, RM55ES  
RM60  
RM65, RM65ES**



---

## 1 Safety Regulations

1. **Always read the operating/assembly instruction books** before using the machine for the first time. Familiarise yourself with the controls and proper use of the equipment. Learn how to stop the engine quickly.
2. **Only use the mower for the purpose for which it was designed (cutting and collecting grass).** Other use can be hazardous and damaging to the machine.
3. **Never allow children or people unfamiliar with these instructions to use the mower.**
4. **Never use the lawnmower** when people (especially children) or pets are nearby, or after taking medication or substances that can affect reactions/concentration.
5. **Remember that the operator or user is responsible for accidents or hazards occurring to other people or their property.**
6. **Always check oil and fuel levels before use. The Honda engines take 0.45 litre of oil. All the others take 0.6 litre.** Any shortage can be serious.
7. **Make sure the lawn is clear** of stones or other debris that could be thrown up by the blade. Clear twigs away from beneath trees and shrubs.
8. **Stop the engine and disconnect the H.T. lead** (spark plug cap) before carrying out any work on the mower. It is a simple push fit.
9. For inspecting the under side **always tip the mower backwards.**
10. **Regularly check** the cutter blade bolt and all other nuts and bolts around the machine, and the condition of the cutter blade. A worn or out-of-balance cutter blade can cause unnecessary vibration and failure of components.
11. **Do not use the mower on slopes exceeding a 20° incline (15%).** Engine seizure may result. Cut up the slope, and bring the mower down backwards.
12. **If the mower is used without the grassbag** the rear deflector must be in place.
13. **Remember that the cutter blade continues to rotate** after the machine is switched off and does not stop until the engine is stationary.
14. **Keep hands and feet away from the cutter blade.** Wear protective shoes. Never mow in open-toed sandals or similar.
15. **Petrol is a fire hazard.** Do not expose to a naked flame. Always allow the engine to cool slightly before refuelling.
16. **Do not operate the engine in an enclosed area.** Exhaust gases contain carbon monoxide.

**Engine Model: RM55, RM55ES  
RM60  
RM65, RM65ES**



---

## **2 Fuel, Oil, Air Filter and Spark Plug Requirements**

**FUEL** – these are 4-stroke petrol engines. The correct fuel is ordinary unleaded petrol.

NOTE: These engines have dual fuel capability and so bio-fuels may be used without additional adjustment to the engine.

**OIL** – the correct oil to use is Mountfield MX855 oil, or a 4-stroke SAE 30 or or 10W-30 multi-viscosity oil. DO NOT mix oil with the fuel. The dipstick shows the minimum and maximum levels. The engine holds 0.6 litre of oil.

The use of multi-viscosity oils in hot temperatures will result in a higher than normal oil consumption. It is important, therefore, to check the oil level more frequently.

Do not mix oils of different brands and features.

Do not over-fill with oil. Over-filling may cause smoking or contamination of the spark plug and/or air filter.

**AIR FILTER** – these engines use a cleanable (warm soapy water) sponge air filter.

**SPARK PLUG** – the following sparkplug is the correct specification:

**Champion: RN9YC**

The spark plug gap should be 0.76mm or 0.03” (<sup>30</sup>/<sub>1000</sub>)

**Engine Model: RM55, RM55ES  
RM60  
RM65, RM65ES**



---

### 3 Routine Engine Maintenance

Regular and careful maintenance is essential to preserve the original performance and safety level of the engine. Always store the mower in a dry place.

#### TESTING FOR A SPARK (this job requires 2 people)

1. Stand the machine on a firm surface and set the height adjusters to the lowest setting for added safety.
2. Remove the H.T. lead (1 in the diagram) – a push/pull fit.
3. Unscrew the spark plug (2 in the diagram) with a genuine spark plug spanner.
4. Fit the plug back into the end of the HT Cap and rest it against the engine block (hold only the black insulation lead).
5. The second person can now hold in the Operator Presence Control (OPC) and pull the engine cord. You should see a spark jump across the end of the plug.

#### H.T. Lead (spark plug cap) and Spark Plug

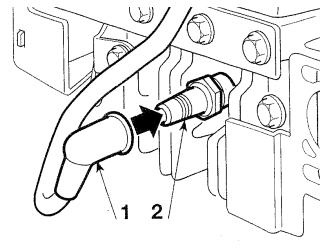

**Engine:**  
RM55,  
RM55ES  
RM60, RM65,  
RM65ES

**Spark Plug:**  
Champion: RN9YC

The spark plug gap for all these engines should be 0.76mm or 0.03" ( 30/1000 ).

#### DRAINING FUEL:

We advise that the engine should be drained of fuel before storage for more than 30 days. One should only buy fuel in quantities that can be used up within a few weeks.

How to drain the fuel is explained in sub-section A of Section 4 Starting the Engine.

Alternatively, because this engine has a gravity feed, the engine may be allowed to run until it runs out of petrol. For convenience during this process, the engine can be made to run on its own by simply securing the OPC lever against the handle and leaving the mower on a flat, level and solid surface with the height of cut set to the lowest setting. **Ensure there are no children or pets unsupervised nearby.**

**Engine Model: RM55, RM55ES  
RM60  
RM65, RM65ES**



## CHANGING ENGINE OIL

### Check the engine oil before each use.

These small four stroke engines hold up to 0.6 litres of oil (1.2 Pints). Any oil shortages can cause premature wear or serious damage to the engine. So too will using the incorrect grade of oil. NB Wipe the dipstick, then fully replace/withdraw it to gain an accurate reading.

Mountfield MX855 four stroke oil is readily available through either the B&Q chain of retailers or through our own comprehensive dealer network.

If you are unable to obtain the correct oil, use either an SAE30 or a 10W-30 grade of oil. These oils are generally only found in the larger DIY stores in the gardening department or at a garden centre or lawnmower specialist.

The oil should be changed on all new engines after approximately 5 hours of operation. It should then be changed every 25 hours of operation, or once a season.

Before changing the oil, run the engine for a few minutes to warm the engine oil. This allows it to run more freely and to carry out any sediment with it.

### **Easiest way to drain excess oil (from oil-fill tube):**

Run the engine a few minutes to warm the oil. Remove the H.T. lead and grass catcher assembly. Undo the oil fill dip stick and make sure a suitable tray is in place to catch the oil. Tilt the machine **backwards onto the rear right wheel closest to the oil fill** (three wheels will be clear of the ground). As the angle increases the oil will pour out of the fill and into the tray. Once empty, stand the machine on level ground and refill as per the operating instructions.

*These engines do have a drain plug (a 13mm bolt head) beneath the cutter deck beside the main crankshaft (blade shaft). It is concealed above a black plastic belt guard which protects the belt. Inside is a small recess with the oil drain bolt at the top. Turn the drain bolt anti-clockwise to release.*

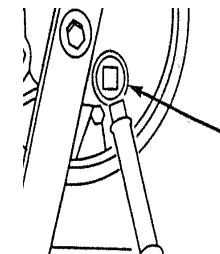

### Engine Oil

- **Mountfield MX855**
- **SAE30 lawnmower oil**
- **10W-30 oil**

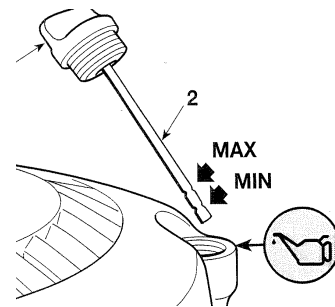

### **Oil capacity is 0.6 litre**

*Mountfield MX855 four stroke oil is readily available through either the B&Q chain or through our own dealer network. **itre***

Engine Model: RM55, RM55ES  
RM60  
RM65, RM65ES



---

### Battery Care (for key-start models only):

**These guidelines for the care of lawnmower batteries should be observed. If not, a shortened working life of the battery may result. These are duplicated in the Owners Instruction pack supplied with the lawnmower.**

1. Always read the instructions carefully in the owner's manual which is supplied with the engine.
2. Before attempting to start a new engine on the key, charge the battery for 48 hours continuously (use only the battery charger supplied with the machine) and then leave to rest for 12 hours.
3. **Beware!** Do **not** recharge the battery using an incorrect charger (i.e. car battery charger). Serious damage may occur. Always check the charger plug is connected to the battery socket. On some machines the battery is hidden.
4. Frequent stopping and restarting of the engine may result in a low battery charge. In this instance it is recommended that the battery be charged over night once a month during the cutting season, more frequently if heavily used.
5. Never store a battery which is discharged. This may result in permanent damage.
6. Disconnect the battery from the circuit if the machine is to be unused for more than 15 days.
7. At the end of the season and before storing for the winter, charge the battery for 24 hours and store away from the machine in a cool dry place.
8. Before using the machine the following spring, recharge the battery for 48 hours and then leave to rest for 12 hours. .
9. The battery is sealed and does not need any maintenance other than that suggested in the above points.

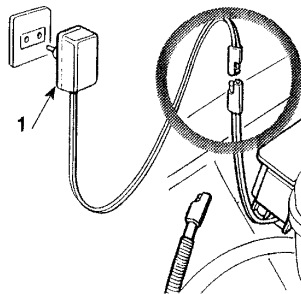

**Engine Model: RM55, RM55ES  
RM60  
RM65, RM65ES**



## 4 Starting the Engine

### The correct way to start the mower:

Check the engine oil, and there is sufficient clean/fresh petrol in the fuel tank.

1. Ensure the machine is on a firm level surface (path, patio or short grass). Check the underside is clear from old lawn debris. If you have to tilt the mower, do this backwards only.
2. Check the H.T. lead (spark plug cap) is correctly fitted to the spark plug.
3. Set the throttle to CHOKE before starting (this may be necessary even when the engine is warm).
4. Check the OPC lever (it may be marked STOP) is held against the handle when starting and using the mower. Pull the cord to start the engine, and once running set the throttle to FAST.
5. **FOR KEY START MODELS** hold the OPC lever (it may be marked STOP) against the handle when starting and using the mower. Either turn the key or pull the cord to start the engine, and once running set the throttle to FAST.

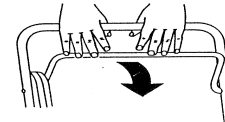
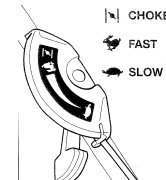
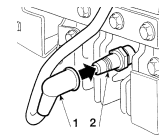

### QUICK TROUBLESHOOTING GUIDE:

**Problem:**

**Engine is difficult to start**

**Likely Cause:**

- No fuel
- Stale fuel or build-ups in fuel tank
- Spark plug disconnected
- Dirty plug or incorrect gap
- Air lock
- Micro switch not engaging
- Loose connection or flat battery (electric start models only)

**Solution:**

- Check and top up (see A)
- Drain old fuel, re-fill with fresh fuel (see A)
- Check the spark plug cap is firmly fitted on the spark plug (see B)
- Check the spark plug (see B)
- Bleed air from fuel supply (see C)
- Adjust (see D)
- Check (see E)

**No response from key start**

Engine Model: RM55, RM55ES  
RM60  
RM65, RM65ES



**A: Fuel requirements:**

***These engines run on ordinary un-leaded fuel. The fuel tank holds 1.2 litre.***

***Stale fuel or build-ups in the fuel tank are most common when the mower has been stored for a period of time (e.g. over the winter period)***

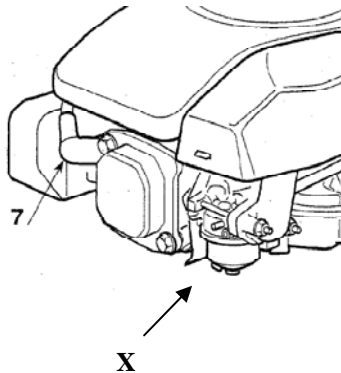

The fuel tank on these gravity-fed engines breathes through the thread on the fuel cap. An air lock may be created if the fuel cap is too tight.....this would cause the engine to cut out. The remedy is to remove the fuel cap to let air back into the tank, replace the cap and tighten it just finger-tight.

Because fuel can separate over a period of time we advise that the engine be drained of fuel before storage for more than 30 days. One should only buy fuel in quantities that can be used up within a few weeks.

**When emptying stale fuel from the engine place the mower on a solid surface, or patch of gravel or similar (fuel spillage may kill the lawn/stain a patio).**

To drain the fuel, remove the spark plug cap (for safety), remove the air filter (for visibility), and tilt the mower BACKWARDS.

Viewed from the front, to the right of the spark plug (7) and below the front of the air filter you will see the float bowl on the carburettor. A bolt holds the bowl in place on the very bottom, but on an angle slightly closer to you is another bolt with a red washer (X).

With a 10mm spanner undo this bolt on the angle and remove it (taking care not to lose the red washer). Allow the petrol to drain completely from the tank before replacing the bolt. Refill the tank with fresh unleaded fuel.

**Engine Model: RM55, RM55ES  
RM60  
RM65, RM65ES**



**B: Spark plug:**

1. Check the H.T. lead (spark plug cap) is correctly fitted to the spark plug. To test for a spark see 2-6 below.
2. Stand the machine on a firm surface and set the height adjusters to the lowest setting for added safety.
3. Remove the H.T. lead (1 in the diagram) – a push fit.
4. Unscrew the spark plug (2 in the diagram) with a genuine spark plug spanner.
5. Fit the plug back into the end of the H.T. lead and rest it against the engine block (hold only the black insulation lead).
6. The second person can now hold in the OPC and pull the engine cord. Watch for a spark jump across the end of the plug.

Oil on the spark plug will prevent any spark. To clean oil from the spark plug, remove and clean the spark plug completely. **ONLY USE A GENUINE SPARK PLUG SPANNER OR A 21mm BOX SPANNER.**

With the sparkplug removed, hold in the OPC and pull the engine over with the pull cord 6 times to eject any oil from the spark plug hole. Replace the plug and start the engine in the normal way. The engine may smoke at first, but allow the engine to continue running for at least ten minutes. The smoke will begin to dissipate. Allow to run until the smoke clears.

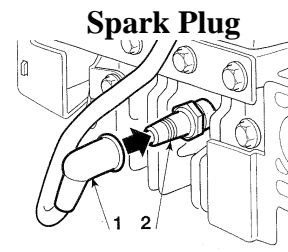

**NB** To test for a spark it requires 2 people

**Spark Plug:  
Champion RN9YC**

**The spark plug gap for these engines is 0.76mm or 0.03" ( 30/1000 ).**

**C: Bleeding air from the fuel supply:**

If fuel is not reaching the cylinder it may be there is air trapped in the fuel supply. To resolve this, place the mower on a solid surface, or patch of gravel or similar (fuel spillage may kill the lawn or stain a patio):

Viewed from the front, to the right of the spark plug (7) and below the front of the air filter you will see the float bowl on the carburettor. A bolt holds the bowl in place on the very bottom, but on an angle slightly closer to you is another bolt with a red washer (X).

With a 10mm spanner undo this bolt on the angle until petrol flows freely. Re-tighten this bolt.

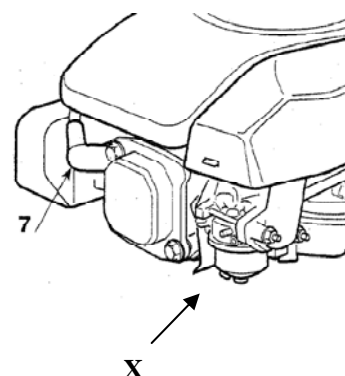

**Engine Model: RM55, RM55ES  
RM60  
RM65, RM65ES**



**D: Adjusting the micro switch:  
(NB DOES NOT APPLY TO SP536 and SP536ES)**

1. Hold the OPC bar gently in to the main handle and listen for a faint click coming from the back left hand corner of the engine. You are checking here for a micro-switch engaging which allows the electrical feed to the spark plug. If there is no audible click it may be that the micro-switch is not fully engaged.

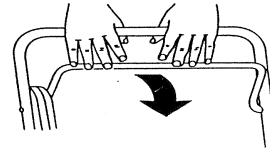

2. In this case, follow the OPC cable down to the back left hand corner of the engine where the lever moves when the OPC is depressed. Come BACKWARDS along the bare metal cable (2) some 8cms to where the metal bracket (5) grips the black plastic cable covering (directly below the fuel filler).

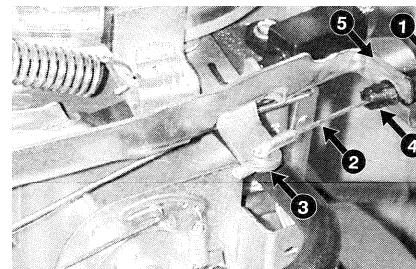

3. Release the plastic cable cover by compressing the 2 lugs (4) inwards on the plastic cable cover that are splayed out and hold it in place. Feed the black plastic cable cover BACKWARDS through the bracket (5).
4. With a pair of pliers bend the metal bracket BACKWARDS 4 mm towards the handle. and then replace the cable in the bracket. This will now engage the micro-switch by pulling it further, and you should now be able to start the mower in the normal way.

**E: No response from key start (electric start models only):**

Before attempting to start a new engine on the key, charge the battery for 48 hours continuously (use only the battery charger supplied with the machine) and then leave to rest for 12 hours.

Frequent stopping and restarting of the engine may result in a low battery charge. In this instance it is recommended that the battery be charged over night once a month during the cutting season, more frequently if heavily used.

The battery charger should feel slightly warm if working correctly when attached to both mains and battery.

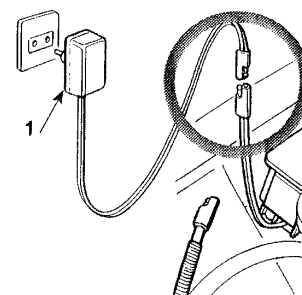

**Engine Model: RM55, RM55ES  
RM60  
RM65, RM65ES**



Check the cables leading from the battery are connected to the cables coming down the handle from the key start. Check also the cables are attached firmly to the terminals on the battery.



Check the cables leading from the back of the key start (beneath the handle) are securely attached to the terminals on the starter key unit.

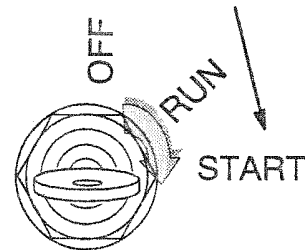

If there is still no response from the starter unit (remember the OPC must be held in when starting the engine), contact your local service dealer.

**Battery Care Guidelines – these should be observed. If not, a shortened working life of the battery may result.**

1. Always read the instructions carefully in the owner's manual which is supplied with the engine.
2. Before attempting to start a new engine on the key, charge the battery for 48 hours continuously (use only the battery charger supplied with the machine) and then leave to rest for 12 hours.
3. **Beware!** Do **not** recharge the battery using an incorrect charger (i.e. car battery charger). Serious damage may occur. Always check the charger plug is connected to the battery socket. On some machines the battery is hidden. It is advisable to remove the battery altogether and charge it away from the lawnmower.
4. Frequent stopping and restarting of the engine may result in a low battery charge. In this instance it is recommended that the battery be charged over night once a month during the cutting season, more frequently if heavily used.
5. Never store a battery which is discharged. This may result in permanent damage.
6. Disconnect the battery from the circuit if the machine is to be unused for more than 15 days.
7. At the end of the season and before storing for the winter, charge the battery for 24 hours and store away from the machine in a cool dry place.
8. Before using the machine the following spring, recharge the battery for 48 hours and then leave to rest for 12 hours.
9. The battery is sealed and does not need any maintenance other than that suggested in the above points.

Engine Model: RM55, RM55ES  
RM60  
RM65, RM65ES



## 5 Engine Starts and Smokes Heavily

### QUICK TROUBLESHOOTING GUIDE:

**Problem:**

**White, blue or grey smoke from exhaust**

**Likely Cause:**

- Over-filled with oil
- Mower has been tipped incorrectly

**Solution:**

- Reduce oil (see A)
- Remove oil from cylinder (see B)

**Oil coming from exhaust**

- Over-filled with oil
- Mower has been tipped incorrectly

- Reduce oil (see A)
- Remove oil from cylinder (see B)

**A:** 1. Do not overfill the engine with oil.

These 4-stroke engines hold up to 0.6 litres of oil (1.2 Pints). NB Wipe the dipstick, then fully replace/withdraw it to gain an accurate reading.

#### Easiest way to drain excess oil (from oil-fill tube):

Run the engine a few minutes to warm the oil. Remove the H.T. lead and grass catcher assembly. Undo the oil fill dip stick and make sure a suitable tray is in place to catch the oil. Tilt the machine **backwards onto the rear right wheel closest to the oil fill** (three wheels will be clear of the ground). As the angle increases the oil will pour out of the fill and into the tray. Once empty, stand the machine on level ground and refill as per the operating instructions.

*These engines do have a drain plug (a 13mm bolt head) beneath the cutter deck beside the main crankshaft (blade shaft). It is concealed above a black plastic belt guard protects the belt. Inside is a small recess with the oil drain bolt at the top. Turn the drain bolt anti-clockwise to release.*

#### Engine Oil:

- **Moutfield MX855**
- **SAE30 lawnmower oil**
- **10W-30 oil**

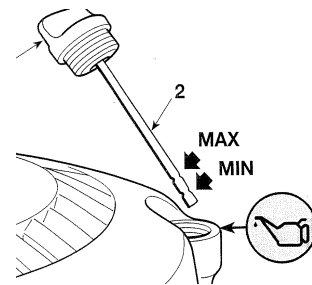

#### Oil capacity is 0.6 litre

*Moutfield MX855 four stroke oil is readily available through either the B&Q chain or through our own dealer network.*

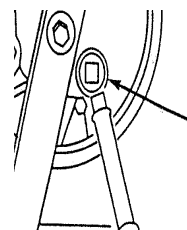

2. Now follow the instructions in B below.

**B:** This is a general indication that the mower has been over-filled with oil, or tipped incorrectly (perhaps inadvertently). It can be resolved without the intervention of a service dealer.

1. Place the mower on a level surface (not the lawn or a good patio). Check the oil level in the sump, top up if necessary. Check the level of fuel in the tank and top this up (the mower once started may need

**Engine Model: RM55, RM55ES  
RM60  
RM65, RM65ES**



---

to run for up to 40 minutes). Remove the air filter assembly located on the left hand side of the engine (***viewed from the back***).

2. The filter should be just sticky to the touch with oil. If very oily, clean the foam filter in hot soapy water, dry and lightly oil it. Squeeze to remove any excess oil.
3. Remove and clean the spark plug completely. **ONLY USE A GENUINE SPARKPLUG SPANNER OR A 21mm BOX SPANNER.**

With the sparkplug removed, hold in the OPC and pull the engine over with the pull cord 6 times to eject any oil from the spark plug hole.

4. Replace the plug and start the engine in the normal way. The engine will smoke quite badly at first, but allow the engine to continue running for at least ten minutes. The smoke will begin to dissipate. Never mow any grass with the air filter removed.
5. Stop the engine and refit the cleaned and correctly-oiled air filter.

For convenience during the above process, the engine can be made to run on its own by simply securing the OPC lever against the handle and leaving the mower on a solid surface with the height of cut set to the lowest setting.

***Ensure there are no children or pets unsupervised nearby.*** Allow to run for a further 30 - 40 minutes until the smoke clears.

NB During subsequent uses (for maybe a further 8-10 hours) the mower may smoke a little. Droplets of oil may come from the exhaust onto the deck as the oil is cleared from the cylinder. Simply wipe these away with an old rag.

**The correct way to tip your mower is BACKWARDS.**

Engine Model: RM55, RM55ES  
RM60  
RM65, RM65ES



## 6 Engine Cutting Out or Running Unevenly

### QUICK TROUBLESHOOTING GUIDE:

**Problem:**

**Engine hunts  
briefly and stops**

**Likely Cause:**

- Fuel cap too tight

**Solution:**

- Loosen cap (see A)

**Engine hunts  
continuously**

- Dirt in fuel supply
- Air drawn into the engine from  
a faulty manifold

- Replace fuel (See B)
- Refer to dealer

**A:** The fuel tank on these gravity-fed engines breathes through the thread on the fuel cap. An air lock may be created if the fuel cap is too tight. Typically, the engine will not re-start for a period of minutes.

**SOLUTION:** Remove the fuel cap to let air back into the tank, replace the cap and tighten it just finger-tight.

NOTE: Air trapped in the carburettor may still stop the engine starting. If so, place the mower on a solid surface, or patch of gravel or similar (fuel spillage may kill the lawn or stain a patio):

1. Remove the spark plug cap (for safety), tilt the mower BACKWARDS.
2. Viewed from the front, to the right of the spark plug (7) you will see the float bowl on the carburettor. A bolt holds the bowl in place on the very bottom, but on an angle slightly closer to you is another bolt (X).
3. With a 10mm spanner undo this bolt until petrol flows freely to bleed the carburettor of any trapped air. Tighten the bolt once petrol is flowing freely, replace the spark plug cap and the air filter.

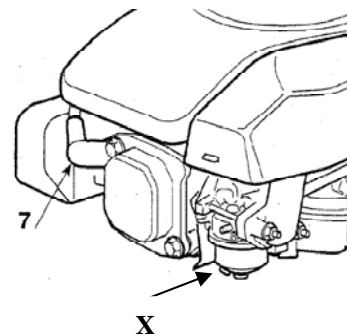

**B:** With the mower on a solid surface, patch of gravel or similar..... follow the points above, but in step 3 REMOVE the bolt (taking care not to lose the red washer). Allow the petrol to drain completely from the tank before replacing the nut. Refill the tank with fresh fuel, and replace the spark plug cap and air filter.

**We advise the engine should be drained of fuel before storage for more than 30 days. One should only buy fuel in quantities that can be used within a few weeks.**

**Engine Model: RM55, RM55ES  
RM60  
RM65, RM65ES**



---

## 7 Pull Cord Not Pulling or Snatching Back

### QUICK TROUBLESHOOTING GUIDE:

<b>Problem:</b>	<b>Likely Cause:</b>	<b>Solution:</b>
<b>Pull cord will not pull</b>	<ul style="list-style-type: none"><li>• OPC not engaged</li><li>• "Hydraulic lock"</li></ul>	<ul style="list-style-type: none"><li>• Hold OPC in (see A)</li><li>• Remove oil from cylinder (see B)</li></ul>
<b>Cord snatches back</b>	<ul style="list-style-type: none"><li>• Blade rotation is impeded</li><li>• Blade is unbalanced or damaged</li></ul>	<ul style="list-style-type: none"><li>• Free blade (See C)</li><li>• (See D) and refer to dealer</li></ul>

**A:** The Operator Presence Control (OPC) safety bar/lever must be held fully in to the main handle before the pull cord can be pulled and the engine can run. If the OPC is fully engaged and the cord will only pull out 4" or so, see **B** below.

**B:** Hydraulic Lock occurs if the mower has been tilted forwards and oil settles between the piston and cylinder head, sticking the piston to the cylinder roof.

1. Remove the spark plug completely. **ONLY USE A GENUINE SPARKPLUG SPANNER OR A 21mm BOX SPANNER.** Do not replace the plug yet.

Now hold the OPC in and pull the cord to free the piston. If the cord will not pull free, tilt the mower **BACKWARDS**, reach underneath and turn the blade (in either direction) to free it. Clear any grass blockage.

2. Hold the OPC in and pull the engine over six times with the cord to eject any oil from the spark plug hole.
3. Wipe the spark plug clean of any oil, replace the plug and test the cord.
4. It would be prudent to also check the air filter assembly for oil contamination if the mower has been tilted incorrectly, as this could lead to a smoking engine, or further difficult starting.

**Engine Model: RM55, RM55ES  
RM60  
RM65, RM65ES**



**C:** The engine pull cord may snatch back when pulled if the machine is not on a flat and firm surface, or the blade and/or its mounting boss are damaged or fitted insecurely.

1. Ensure the machine is situated on a firm level surface (path, patio or short grass). Remove the H.T. lead (spark plug cap) for safety. Check the underside of the machine is clear from old lawn debris. If you have to tilt the mower, do this backwards only. First remove the grass catcher, then lift the front wheels until the handles reach the ground at the rear.

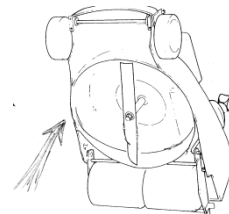

2. If attempting to start the mower on the lawn, the grass beneath the cutter can slow its rotation, and even prevent the free rotation of the cutter, causing a "snatch back". If the engine is cold, select a firm surface for starting the mower. If the engine is warm, always pull the mower back onto a pre-mown area where the grass is already short to prevent unnecessary jamming.

**D:** To check the blade, remove the H.T. lead (spark plug cap) or safety and remove the grass catcher from the rear of the mower. Tilt the mower **BACKWARDS** so that the handle touches the ground.

1. The cutter bar is retained by a central bolt. This should be tight (the thread is the normal anti-clockwise turn to slacken).

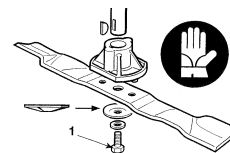

2. To either side of the central bolt there are two silver lugs protruding through the cutter bar. If these are missing, it indicates that the machine has come into contact with more than normal grass and has damaged the cutter mount (boss). This will have to be replaced. This type of repair would not normally be covered by warranty.

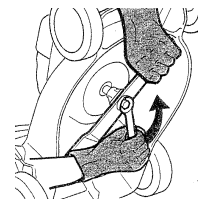

It is wise to mark the blade before removing it so that the blade can be replaced the correct way up.

Engine Model: RM55, RM55ES  
 RM60  
 RM65, RM65ES



## 8 Cutting and Collecting Grass, Vibration

### QUICK TROUBLESHOOTING GUIDE:

<b>Problem:</b>	<b>Likely Cause:</b>	<b>Solution:</b>
<b>Mower will not cut grass properly</b>	<ul style="list-style-type: none"> <li>• Technique is incorrect</li> <li>• Grass is too long or wet</li> <li>• Problem with the blade or blade mounting</li> </ul>	<ul style="list-style-type: none"> <li>• See A</li> <li>• See A</li> <li>• See B</li> </ul>
<b>Mower vibrates excessively</b>	<ul style="list-style-type: none"> <li>• Problem with the blade or blade mounting</li> <li>• The engine mounting is loose</li> </ul>	<ul style="list-style-type: none"> <li>• See B</li> <li>• See B</li> </ul>
<b>Mower will not collect grass properly</b>	<ul style="list-style-type: none"> <li>• Technique is incorrect</li> <li>• Grass is too long or wet</li> <li>• Build-up of grass clippings underneath or lack of air flow</li> </ul>	<ul style="list-style-type: none"> <li>• See A</li> <li>• See A</li> <li>• See C</li> </ul>

### A MOWER WILL NOT CUT GRASS PROPERLY

<p><b>When cutting grass make sure you are using the machine on full throttle (if one is fitted). If collecting the grass ensure the mulching plug (if available) has been removed.</b></p> <p><b>Do not cut wet grass.</b></p>	<p>Especially in the Spring when the grass may be long and lush, do not attempt to cut too much grass at any one time.</p> <p>If the lawn is several inches in length then raise the height of cut and gradually reduce the lawn in stages to prevent blocking. It may also help to remove the grass catcher, cut the grass first on the highest setting, and work down to lower settings and collecting the grass.</p> <p>If the grass is damp you can attempt to cut the lawn by raising the height of cut to allow a greater airflow, and reducing the lawn to the desired level in stages.</p>
<p>Check the height adjuster levers settings are the same on each wheel and that they are at a level suitable for the grass conditions.</p>	
<p><b>Mulching Mowers:</b></p> <p>The same advice above applies to mulching mowers. These are mowers that are not designed to collect grass. Instead they recycle the grass clippings, and grass becomes fertilizer for your lawn</p> <p>To obtain the perfect cutting height you need to work down from the maximum height setting in steps until you reach your ideal height.</p>	

Engine Model: RM55, RM55ES  
 RM60  
 RM65, RM65ES

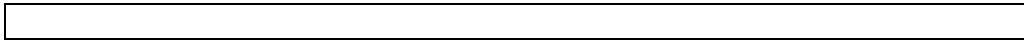

**B PROBLEMS WITH THE BLADE OR BLADE MOUNTING**

<p><b>Before checking the blade, REMOVE the H.T. lead (1 in the diagram). and ONLY TIP THE MOWER BACKWARDS.</b></p>		
<p><b>Excessive vibration can indicate damage to the blade, or blade mounting, or that the engine is loose</b></p> <p><b>Loosening the blade</b>        (it is a normal thread, so turn anti-clockwise to remove the blade)</p>	<p>Check the blade bolt is tight.</p> <p><i>WARNING: Mark the blade before attempting to remove it. This will enable you to replace it the correct way up.</i></p> <p>Check the blade mount. The mount has two lugs one either side of the blade securing bolt. If these have sheered then the blade can move.</p> <p>If the blade mount has failed, a replacement can be purchased through your local Moutfield dealer.</p> <p><b>The Blade mount is only likely to fail because the blade has come into contact with an obstruction of some form.</b> The blade mount is designed to fail in order to protect the engine crankshaft.</p> <p>Check the condition of the cutter blade - if badly worn or damaged, replace with a new one. If a new cutter blade has been fitted, check that it has been installed the correct way up (the wing tips at either end should bend upward into the mower chassis and not downward towards the ground).</p> <p>Check that all 3 bolts securing the engine are in place and tight.</p>	

Engine Model: RM55, RM55ES  
RM60  
RM65, RM65ES



## C BUILD-UP OF GRASS CLIPPINGS UNDERNEATH or LACK OF AIRFLOW

<p><b>When cutting grass make sure you are using the machine on full throttle (if one is fitted).</b></p> <p><b>Raising the height of cut increases airflow and assists grass collection. This is especially so if the grass is damp.</b></p> <p><b>Reducing the height of cut in stages to achieve the desired level is a sound strategy.</b></p>	<ol style="list-style-type: none"><li>1. Ensure there is no build up of grass underneath the casing. <b>Before checking the underside, make sure to remove the HT Cap (sparkplug cap).</b> Only access the under side of the machine by removing the grass catcher then lifting the machine from the front until the handles touch the ground at the rear).</li><li>2. Check the grass catcher allows air to pass through it. If heavily soiled, wash it in warm soapy water to clear old deposits of grass juices and debris. A good airflow is essential for efficient grass collection.</li><li>3. If grass is very long, remove the grass catcher, and work with the deflector plate in position. Clippings can be collected after a few hours drying by simply going over the lawn again with the grass catcher fitted, and the wheels set slightly higher.</li><li>4. Should the machine become blocked with grass when using it, <b>stop the mower and remove the H.T. lead (spark plug cap).</b> Remove the grass box, insert your hand through the rear aperture and clean away any build up of grass clippings. <b>DO NOT TIP THE MOWER FORWARDS, OR SIDEWAYS, OR UPSIDE DOWN.</b></li><li>5. Walk around to the front of the mower and raise the front wheels in the air until the handles reach the ground at the rear. Clean away any grass clippings which have accumulated on the underside.</li><li>6. Once cleaned, lower the machine, re-fit the HT lead (spark plug cap) and restart machine.</li></ol>
--	--

**Engine Model: RM55, RM55ES  
RM60  
RM65, RM65ES**



---

## 9 Transportation and Handling

The correct way to gain access underneath the mower:

**Before checking the underside, make sure to remove the HT Cap (sparkplug cap).**

**ALWAYS lift from the front of the mower so that the front wheels are raised, and the handles touch the ground at the rear. Do not tip the mower sideways or forward (like one might lift a wheelbarrow) as this can flood the air filter, exhaust and even the cylinder with engine fluids.**

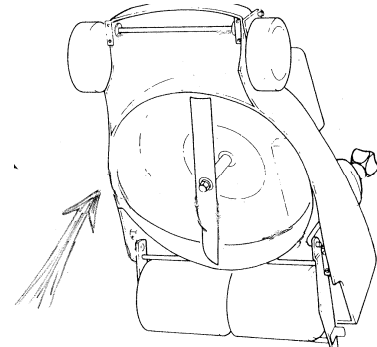

It may be helpful to place a weight on the handle to maintain the mower in this position when working beneath the deck.

**Whenever the machine is to be handled, raised onto a workbench or transported, remove the HT Cap (sparkplug cap):**

1. Wearing strong gloves and taking account of the weight and its distribution, grasp the machine at the points that offer a safe grip.
2. Use an appropriate number of people for the weight of the machine and the characteristics of the vehicle or the place where it has to be placed or collected.
3. When lifting the machine to and from a vehicle or onto a workbench, take care to keep it level. **DO NOT TIP IT.**
4. The handles may be folded to ease storage and transportation. It is important to take care not to trap the operating cables when collapsing the handles.

Engine Model: RM55, RM55ES  
RM60  
RM65, RM65ES



---

## 10 Maintenance and Storage

Regular and careful maintenance is essential to preserve original performance and safety levels of the engine. Always store the mower in a dry place. Please also refer to the Engine Routine Maintenance information for additional help.

### Key maintenance and storage information (all engines):

1. **Keep all nuts, bolts and screws tight** to ensure the equipment is in safe working condition. **Regular routine maintenance** is essential for safety and performance.
2. **Never store the mower** with fuel in the tank inside a building where vapour may reach a flame or a spark or a source of extreme heat.
3. **Allow the engine to cool** before storing in an enclosed space.
4. **To reduce the fire hazard**, keep the engine, exhaust silencer, battery compartment (if fitted) and fuel storage area free of grass, leaves, or excessive grease. Do not leave containers of grass cuttings in rooms.
5. **Check the stone guard and grass collector** frequently for wear and deterioration.
6. **If the fuel tank has to be drained**, this should be done outside and when the engine is cool.
7. **Wear strong work gloves** while removing or assembling the blade.
8. **Keep the blade balanced during sharpening.** All operations on the blade (dismantling, sharpening, balancing, remounting and/or replacing) require a certain familiarity and (in some cases) special tools. For safety reasons these tasks are best carried out by one of our authorised service dealers.
9. **For safety reasons, DO NOT use the equipment with worn or damaged parts.** Parts are to be replaced and not repaired. Use genuine spare parts only. Parts that are not of the same quality can damage the equipment and be dangerous for your safety.

**If the lawnmower is to be stored for more than 28 days (e.g. over the winter period), drain the fuel from the tank or allow the engine to run until it runs out of fuel. This should always be done outdoors. To empty the fuel from the engine, see section 4 Starting the engine, sub-section A.**

Alternatively, because this engine has a gravity feed, the engine can be allowed to run until it runs out of petrol.

For convenience during this process, the engine can be made to run on its own by simply securing the OPC lever against the handle and leaving the mower on a solid surface with the height of cut set to the lowest setting. **Ensure there are no children or pets unsupervised nearby.**

**Engine Model: RM55, RM55ES  
RM60  
RM65, RM65ES**



---

## 11 Guarantee, Spare Parts, Repairs

Congratulations on the purchase of your lawnmower. This product is guaranteed against faulty parts or manufacture for domestic use as shown below:

**MOWER MODEL:**

**462 PD/ES, 463R PD/ES, 483 R,  
483 R/ES, 513 PD/ES, 553 R,  
553 R/ES  
SP536, SP536ES**

**SP554, SP534ES**

**M43 PD, M63 PD, M63 PD/ES**

**GUARANTEE PERIOD:**

**2 years from the date of purchase**

**2 years from the date of purchase on  
the engine and mower, and 10 years  
anti-corrosion warranty on the deck**

**2 years from the date of purchase on  
the engine and mower, and 20 years  
anti-corrosion warranty on the deck**

If the machine is used commercially the guarantee period is 90 days from the date of purchase.

If your product fails due to a defect in materials or workmanship during the guarantee period it will be repaired or replaced at no charge provided all repairs are carried out by an authorised service dealer. Delivery and collection of the machine is your responsibility, and not covered by this guarantee. To locate your nearest service dealer telephone the helpline on 0845 600 2912.

This guarantee is not transferable. Proof of purchase will be required in the event of a claim. Warranty is subject to the mower receiving annual service where there is a warranty for 2 or more years.

Normal wear-and-tear and the routine replacement of parts which are subject to normal wear-and-tear are not covered by this guarantee. Likewise, any defect which is the result of misuse, alteration, improper assembly or adjustment, neglect or accident is not covered by this guarantee.

This guarantee is in addition to, and does not detract from your original contractual rights under statute or common law.

### Spare Parts, Repairs

We do not supply spares parts direct for general use. We do, however, have a comprehensive Service Link network that can happily supply replacement parts for your mower. Our Service Link centres can also undertake any remedial work requested (work that is not covered by the guarantee will be chargeable). Your local Service Link can be found by contacting the Helpline and quoting the model of mower you have and your postcode. Alternatively, go to [www.servicelink.org.uk](http://www.servicelink.org.uk)  
**Our Helpline service, telephone 0845 600 2912 (Monday to Saturday 9am – 5pm, and Sunday 10am – 4pm).**