

Engine Model: Honda GCV135  
and  
Honda GCV160

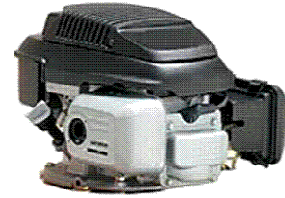

---

# SELF-HELP PROBLEM SOLVING and MAINTENANCE for PETROL LAWNMOWERS

These engines are fitted to the following recent products:

- 422HP
- SP535
- 462 PD
- SP555
- 512 PD
- Cooper 532PD

1. Safety Regulations .....	2
2. Fuel, Oil, Air Filter and Spark Plug Requirements.	3
3. Routine Engine Maintenance .....	4
4. Starting the Engine .....	6
5. Engine Starts and Smokes Heavily .....	9
6. Engine Cutting Out or Running Unevenly .....	11
7. Pull Cord Not Pulling or Snatching Back .....	13
8. Cutting and Collecting Grass, Vibration .....	15
9. Transportation and Handling .....	18
10. Maintenance and Storage .....	19
11. Guarantee Spare Parts, Repairs .....	20

**If, after reading this guide, you feel you are either unsure of what is required, or that you do not have the correct tools to undertake a job yourself, please contact:**

- **Our Helpline service, telephone 0845 600 2912 (Monday to Saturday 9am – 5pm, and Sunday 10am – 4pm), or**
- **Our local Service Link centre who can undertake any remedial work requested (work that is not covered by the guarantee will be chargeable)**



**Your local Service Link centre can be found by contacting the Helpline and quoting the model of mower you have and your postcode. Alternatively, go to [www.servicelink.org.uk](http://www.servicelink.org.uk)**

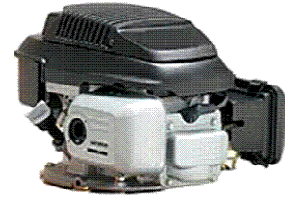

---

## **1 Safety Regulations**

- 1. Always read the operating/assembly instruction books** before using the machine for the first time. Familiarise yourself with the controls and proper use of the equipment. Learn how to stop the engine quickly.
- 2. Only use the mower for the purpose for which it was designed (cutting and collecting grass).** Other use can be hazardous and damaging to the machine.
- 3. Never allow children or people unfamiliar with these instructions to use the mower.**
- 4. Never use the lawnmower** when people (especially children) or pets are nearby, or after taking medication or substances that can affect reactions/concentration.
- 5. Remember that the operator or user is responsible for accidents or hazards occurring to other people or their property.**
- 6. Always check oil and fuel levels before use. This engine takes 0.45 litre of oil.** Any shortage can be serious.
- 7. Make sure the lawn is clear** of stones or other debris that could be thrown up by the blade. Clear twigs away from beneath trees and shrubs.
- 8. Stop the engine and disconnect the H.T. lead** (spark plug cap) before carrying out any work on the mower. It is a simple push fit.
- 9. For inspecting the under side always tip the mower backwards.**
- 10. Regularly check** the cutter blade bolt and all other nuts and bolts around the machine, and the condition of the cutter blade. A worn or out-of-balance cutter blade can cause unnecessary vibration and failure of components.
- 11. Do not use the mower on slopes exceeding a 20° incline (15%).** Engine seizure may result. Cut up the slope, and bring the mower down backwards.
- 12. If the mower is used without the grassbag** the rear deflector must be in place.
- 13. Remember that the cutter blade continues to rotate** after the machine is switched off and does not stop until the engine is stationary.
- 14. Keep hands and feet away from the cutter blade.** Wear protective shoes. Never mow in open-toed sandals or similar.
- 15. Petrol is a fire hazard.** Do not expose to a naked flame. Always allow the engine to cool slightly before refuelling.
- 16. Do not operate the engine in an enclosed area.** Exhaust gases contain carbon monoxide.

**Engine Model: Honda GCV135  
and  
Honda GCV160**

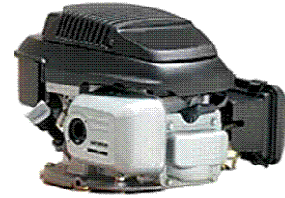

---

## **2 Fuel, Oil, Air Filter and Spark Plug Requirements**

**FUEL** – these are 4-stroke petrol engines. The correct fuel is ordinary unleaded petrol.

**OIL** – the correct oil to use is Mountfield MX855 oil, or a 4-stroke SAE 30 or 10W-30 multi-viscosity oil. DO NOT mix oil with the fuel. The dipstick shows the minimum and maximum levels. The engine holds 0.45 litre of oil.

The use of multi-viscosity oils in hot temperatures will result in a higher than normal oil consumption. It is important, therefore, to check the oil level more frequently.

Do not mix oils of different brands and features.

Do not over-fill with oil. Over-filling may cause smoking or contamination of the spark plug and/or air filter.

**AIR FILTER** – these engines use a paper air filter. This cannot be cleaned if it becomes contaminated with oil or petrol, and must be replaced.

**SPARK PLUG** – the following sparkplug is the correct specification:

**NGK: BPR6ES**

The spark plug gap should be 0.76mm or 0.03” (<sup>30</sup>/<sub>1000</sub>)

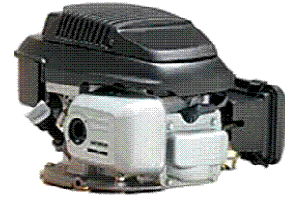

### 3 Routine Engine Maintenance

**Regular and careful maintenance is essential to preserve the original performance and safety level of the engine. Always store the mower in a dry place.**

#### **TESTING FOR A SPARK** (this job requires 2 people)

1. Stand the machine on a firm surface and set the height adjusters to the lowest setting for added safety.
2. Remove the H.T. lead (1 in the diagram) – a push/pull fit.
3. Unscrew the spark plug (2 in the diagram) with a genuine spark plug spanner.
4. Fit the plug back into the end of the HT Cap and rest it against the engine block (hold only the black insulation lead).
5. The second person can now hold in the Operator Presence Control (OPC) and pull the engine cord. You should see a spark jump across the end of the plug.

#### **H.T. Lead (spark plug cap) and Spark Plug**

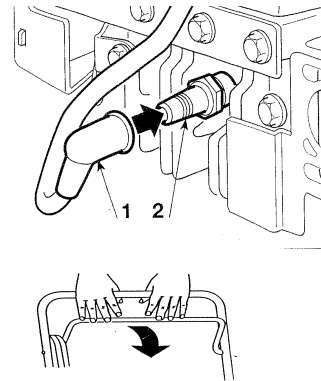

**Spark Plug:  
NGK: BPR6ES**

**The spark plug gap for this engine is 0.76mm or 0.03” ( 30/1000 ).**

#### **DRAINING FUEL:**

We advise that the engine should be drained of fuel before storage for more than 30 days. **When emptying the fuel from the engine place the mower on a solid surface, or patch of gravel or similar (fuel spillage may kill the lawn or stain a patio):**

On the bottom of the carburettor are 2 screw fittings, one on the very bottom of the float bowl which holds the bowl to the carburettor, and one at an angle.

Use a 10mm spanner (a ring spanner is best) to loosen the screw at an angle. Once the screw is loose, fuel will begin to seep out. Allow all the fuel to drain. Before refitting the screw, take about half a cup of clean fresh fuel and pour this into the fuel tank. Rock the machine to rinse around the tank, and again allow this to drain out.

Re-fit the screw. Remove the spark plug from the engine, hold in the OPC and pull the recoil rope 6 times. This will eject any residue of fuel from within the cylinder head. Replace the spark plug.

**Engine Model: Honda GCV135  
and  
Honda GCV160**

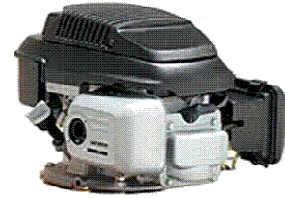

## CHANGING ENGINE OIL

### Check the engine oil before each use.

These small four stroke engines hold up to 0.45 litres of oil (0.9 Pints). Any oil shortages can cause premature wear or serious damage to the engine. So too will using the incorrect grade of oil. NB Wipe the dipstick, then fully replace/withdraw it to gain an accurate reading.

Mountfield MX855 four stroke oil is readily available through either the B&Q chain of retailers or through our own comprehensive dealer network.

If you are unable to obtain the correct oil, use either an SAE30 or a 10W-30 grade of oil. These oils are generally only found in the larger DIY stores in the gardening department or at a garden centre or lawnmower specialist

The oil should be changed on all new engines after approximately 5 hours of operation. It should then be changed every 25 hours of operation, or once a season.

Before changing the oil, run the engine for a few minutes to warm the engine oil. This allows it to run more freely and to carry out any sediment with it.

**There is no drain plug on these engines.....oil is drained from the oil fill**

To drain oil from the oil fill tube, run the engine to warm the oil. Remove the H.T. lead and grass catcher assembly. Undo the oil fill dip stick and make sure a suitable tray is in place to catch the oil. Tilt the machine **backwards onto the rear right wheel (the wheel closest to the oil fill)** so that three wheels will be clear of the ground. As the angle increases the oil will pour out of the fill and into the tray. Once completed, stand the machine on level ground and refilled in accordance with the operating instructions.

### Engine Oil

- **Mountfield MX855**
- **SAE30 lawnmower oil**
- **10W-30 oil**

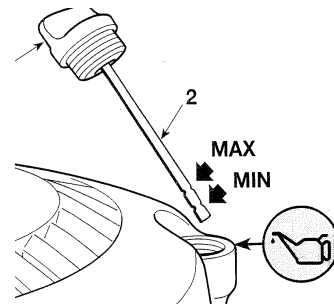

### Oil capacity is 0.45 litre

*Mountfield MX855 four stroke oil is readily available through either the B&Q chain or through our own dealer network.*

**Engine Model: Honda GCV135  
and  
Honda GCV160**

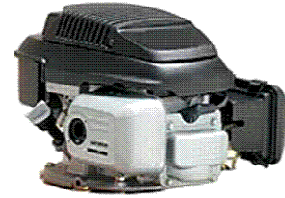

## 4 Starting the Engine

The engine oil should be checked before each use. Check there is sufficient petrol in the fuel tank, and that it is clean and fresh. Old, stale fuel may cause poor starting. Drain stale fuel from the tank and replace with fresh petrol.

1. Ensure the machine is situated on a firm level surface (path, patio or short grass). Check the underside of the machine is clear from old lawn debris. If you have to tilt the mower, do this backwards only. First remove the grass catcher, then lift the front wheels until the handles reach the ground at the rear.
2. Check the H.T. lead (1 in the diagram) is correctly fitted to the spark plug.
3. Ensure that the fuel shut off valve is switched to the ON position.
4. Check the Operator Presence Control (OPC) lever is held against the handle when starting and using the mower.

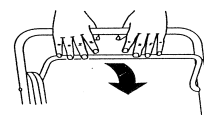
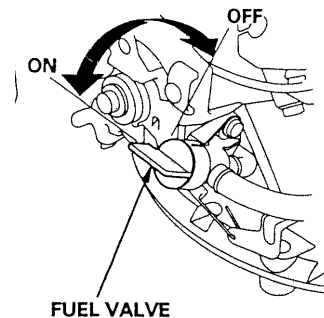
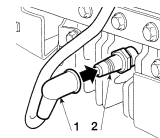
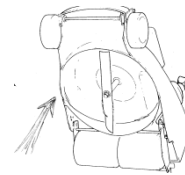

### QUICK TROUBLESHOOTING GUIDE:

**Problem:**

**Engine is difficult to start**

**Likely Cause:**

- Spark plug disconnected
- Dirty spark plug or incorrect gap
- No fuel
- Stale fuel or build-ups in fuel tank

**Solution:**

- Check the spark plug cap is firmly fitted on the spark plug (see A)
- Check the spark plug (see A)
- Check and top up, check fuel is switched ON (see B)
- Drain old fuel, re-fill with fresh fuel (see B)

**Engine Model: Honda GCV135  
and  
Honda GCV160**

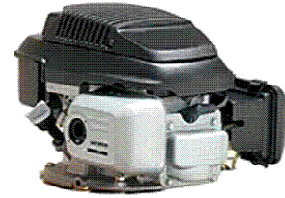

**A: Spark Plug:**

Check the H.T. lead (1 in the diagram) is correctly fitted to the spark plug.

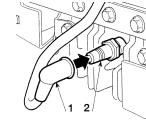

To check the state of the plug, unscrew the spark plug with a genuine spark plug spanner. Oil can be cleaned from it (the result of the machine having been overfilled with oil or tipped incorrectly) with a clean rag.

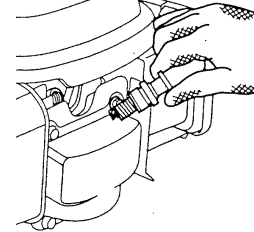

A wire brush or emery paper can be used to clean any carbon deposit from the plug.

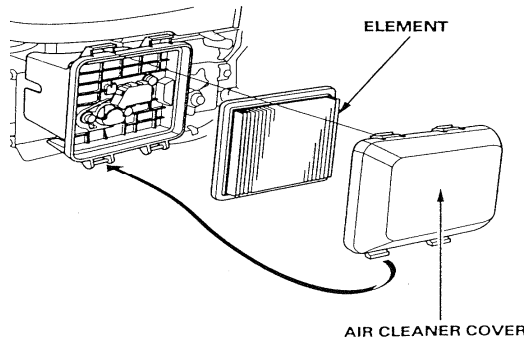

**Now it would be prudent to check the air filter:**

The filter is located on the right hand side of the engine (**viewed from the front**). It is held in place by two clips on the top. Press and remove the cover. The filter element is paper. If contaminated with oil or fuel, it will need to be replaced. Clean the cover and housing from any excess oil. Re-fit the filter.

**If you wish to test for a spark (2 people required):**

1. Stand the machine on a firm surface and set the height adjusters to the lowest setting for added safety.
2. Remove the H.T. lead – a push fit.
3. Unscrew the spark plug with a genuine spark plug spanner.
4. Fit the plug back into the end of the H.T. lead and rest it against the engine block (hold only the black insulation lead).
5. The second person can now hold in the Operators Presence Control and pull the engine cord. You should see a spark jump across the end of the plug.

The spark plug gap should be 0.76mm or 0.03" ( $\frac{30}{1000}$ ).

**Replace the plug and ensure the H.T. lead is correctly fitted to the spark plug.**

**Engine Model: Honda GCV135  
and  
Honda GCV160**

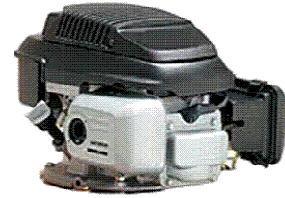

**B: Fuel:**

**Ensure there is fresh unleaded petrol in the fuel tank.** The fuel is fed by gravity.

**Ensure that the fuel shut off valve is switched to the ON position.**

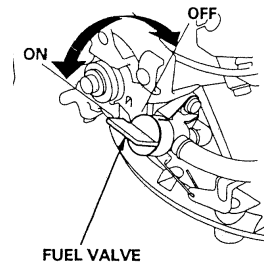

***Stale fuel or build-ups in the fuel tank are most common when the mower has been stored for a period of time (e.g. over the winter period)***

We advise that the engine should be drained of fuel before storage for more than 30 days. One should only buy fuel in quantities that can be used up within a few weeks.

**When emptying the fuel from the engine place the mower on a solid surface, or patch of gravel or similar (fuel spillage may kill the lawn or stain a patio):**

On the bottom of the carburettor are 2 screw fittings, one on the very bottom of the float bowl which holds the bowl to the carburettor, and one at an angle.

Use a 10mm spanner (a ring spanner is best) to loosen the screw at an angle. Once the screw is loose, fuel will begin to seep out. Allow the full contents of the tank to drain through onto the machine chassis and then the floor, or have a small collection tub ready to place underneath to collect the fuel.

Allow all the fuel to drain. Before refitting the screw, take about half a cup of clean fresh fuel and pour this into the fuel tank. Rock the machine to rinse around the tank, and again allow this to drain out.

Re-fit the screw and fill the tank with new fresh unleaded fuel. Before starting, wipe away any spillages from the deck.

Remove the spark plug from the engine and clean it. Whilst the plug is removed, hold in the OPC and pull the recoil rope 6 times. This will eject any residue of fuel from within the cylinder head. Now (if possible) heat the contact end of the spark plug (*the end that is screwed into the cylinder head*) in a gas flame. Refit the spark plug before attempting to start the engine.

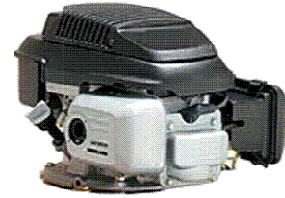

## 5 Engine Starts and Smokes Heavily

### QUICK TROUBLESHOOTING GUIDE:

**Problem:**

**White, blue or grey smoke from exhaust**

**Likely Cause:**

- Over-filled with oil
- Mower has been tipped incorrectly

**Solution:**

- Reduce oil (see A)
- Remove oil from cylinder (see B)

**Oil coming from exhaust**

- Over-filled with oil
- Mower has been tipped incorrectly

- Reduce oil (see A)
- Remove oil from cylinder (see B)

### The correct way to tip your mower is **BACKWARDS**.

**A:** Do not overfill the engine with oil.

This 4-stroke engine holds up to 0.45 litres of oil (1.2 Pints). NB Wipe the dipstick, then fully replace/withdraw it to gain an accurate reading.

To drain oil from the oil fill tube, run the engine to warm the oil. Remove the H.T. lead and grass catcher assembly. Undo the oil fill dipstick and make sure a suitable tray is in place to catch the oil. Tilt the machine **backwards onto the rear right wheel (the wheel closest to the oil fill)** so that three wheels will be clear of the ground. As the angle increases the oil will pour out of the fill and into the tray. Once empty, stand the machine on level ground and refilled in accordance with the operating instructions.

**Engine Oil:**

- **Mountfield MX855**
- **SAE30 lawnmower oil**
- **10W-30 oil**

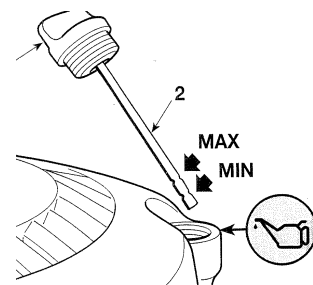

**Oil capacity is 0.45 litre**

*Mountfield MX855 four stroke oil is readily available through either the B&Q chain or through our own dealer network.*

Now follow the instructions in B below.

**Engine Model: Honda GCV135  
and  
Honda GCV160**

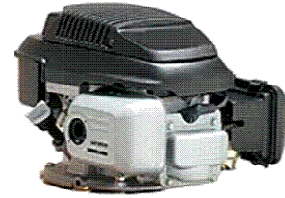

- B:** This is a general indication that the mower has been over-filled with oil, or tipped incorrectly (perhaps inadvertently). It can be resolved without the intervention of a service dealer.

The filter is located on the right hand side of the engine (**viewed from the front**). It is held in place by two clips on the top. Press and remove the cover. The filter element is paper. If contaminated with oil or fuel, it will need to be replaced. Clean the cover and housing from any excess oil. Re-fit the filter.

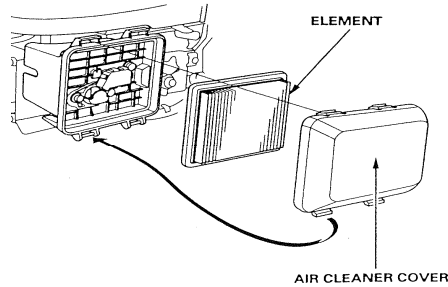

Remove and clean the spark plug completely.  
**ONLY USE A GENUINE SPARKPLUG SPANNER  
OR A 21mm BOX SPANNER.**

Oil can be cleaned from it (the result of the machine having been overfilled with oil or tipped incorrectly) with a clean rag.

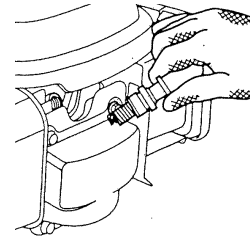

A wire brush or emery paper can be used to clean any carbon deposit from the plug.

With the plug removed, hold in the OPC and pull the recoil rope 6 times. This will rinse and eject any residue of oil from within the cylinder head.

Replace the plug and start the engine in the normal way. The engine will smoke quite badly at first, but allow the engine to continue running for at least ten minutes. The smoke will begin to dissipate. Let the mower run until the smoke has gone.

For convenience during the above process, the engine can be made to run on its own by simply securing the OPC lever against the handle and leaving the mower on a solid surface with the height of cut set to the lowest setting.

**Ensure there are no children or pets unsupervised nearby.** Allow to run for a further 30 - 40 minutes until the smoke clears.

NB During subsequent uses (for maybe a further 8-10 hours) the mower may smoke a little. Droplets of oil may come from the exhaust onto the deck as the oil is cleared from the cylinder. Simply wipe these away with an old rag.

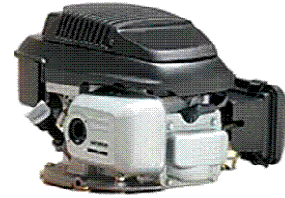

## 6 Engine Cutting Out or Running Unevenly

### QUICK TROUBLESHOOTING GUIDE:

**Problem:**

**Engine revs are very low and maybe uneven**

**Likely Cause:**

- Paper air filter may be contaminated with oil

**Solution:**

- Replace the air filter (see A)

**Engine is hunting (revs go up and down)**

- Dirt or build-ups (or stale fuel) in fuel tank
- Air drawn into the engine from a faulty inlet manifold

- Drain old fuel, re-fill with fresh fuel (see B)
- Refer to a service dealer.

### A: Replacing the Paper Air Filter:

The filter is located on the right hand side of the engine (**viewed from the front**). It is held in place by two clips on the top. Press and remove the cover. The filter element is paper. If contaminated with oil or fuel, it will need to be replaced. Clean the cover and housing from any excess oil. Re-fit a new filter.

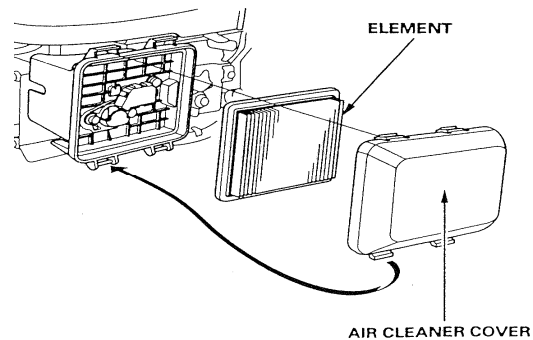

### B: Replacing the Fuel:

**Stale fuel or build-ups in the fuel tank are most common when the mower has been stored for a period of time (e.g. over the winter period)**

**When emptying the fuel from the engine place the mower on a solid surface, or patch of gravel or similar (fuel spillage may kill the lawn or stain a patio):**

On the bottom of the carburettor are 2 screw fittings, one on the very bottom of the float bowl which holds the bowl to the carburettor, and one at an angle.

Use a 10mm spanner (a ring spanner is best) to loosen the screw at an angle. Once the screw is loose, fuel will begin to seep out. Allow the full contents of the tank to drain through onto the machine chassis and then the floor, or have a small collection tub ready to place underneath to collect the fuel.

Allow all the fuel to drain. Before refitting the screw, take about half a cup of clean fresh fuel and pour this into the fuel tank. Rock the machine to rinse around the tank, and again allow this to drain out.

**Engine Model: Honda GCV135  
and  
Honda GCV160**

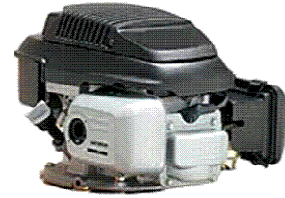

---

Re-fit the screw and fill the tank with new fresh unleaded fuel. Before starting, wipe away any spillages from the deck.

Remove the spark plug from the engine and clean it. Whilst the plug is removed, hold in the OPC and pull the recoil rope 6 times. This will eject any residue of fuel from within the cylinder head. Now (if possible) heat the contact end of the spark plug (*the end that is screwed into the cylinder head*) in a gas flame. Refit the spark plug before attempting to start the engine.

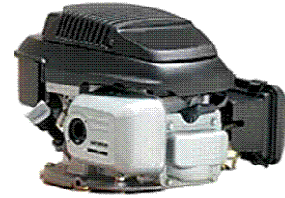

## 7 Pull Cord Not Pulling or Snatching Back

### QUICK TROUBLESHOOTING GUIDE:

<b>Problem:</b>	<b>Likely Cause:</b>	<b>Solution:</b>
<b>Pull cord will not pull</b>	<ul style="list-style-type: none"><li>• OPC not engaged</li><li>• "Hydraulic lock"</li></ul>	<ul style="list-style-type: none"><li>• Hold OPC in (see A)</li><li>• Remove oil from cylinder (see B)</li></ul>
<b>Cord snatches back</b>	<ul style="list-style-type: none"><li>• Blade rotation is impeded</li><li>• Blade is unbalanced or damaged</li></ul>	<ul style="list-style-type: none"><li>• Free blade (See C)</li><li>• (See D) and refer to dealer</li></ul>

**A:** The Operator Presence Control (OPC) safety bar/lever must be held fully in to the main handle before the pull cord can be pulled and the engine can run. If the OPC is fully engaged and the cord will only pull out 4" or so, see **B** below.

**B:** Hydraulic Lock occurs if the mower has been tilted forwards and oil settles between the piston and cylinder head, sticking the piston to the cylinder roof.

Remove and clean the spark plug completely. ONLY USE A GENUINE SPARKPLUG SPANNER OR A 21mm BOX SPANNER. Do not replace the plug yet.

If the cord will not pull free, tilt the mower BACKWARDS, reach underneath and turn the blade (in either direction) to free it. Clear any grass blockage.

With the sparkplug removed, hold in the OPC and pull the engine over with the pull cord 6 times to eject any oil from the spark plug hole.

Replace the plug and start the engine in the normal way. The engine might smoke quite badly at first, but allow the engine to continue running for at least ten minutes. The smoke will begin to dissipate. Let the mower run until the smoke has gone.

For convenience during the above process, the engine may be made to run on its own by simply securing the OPC lever against the handle and leaving the mower on a solid surface with the height of cut set to the lowest setting.

**Ensure there are no children or pets unsupervised nearby.** Allow to run for a further 30 - 40 minutes until the smoke clears.

NB During subsequent uses (for maybe a further 8-10 hours) the mower may smoke a little. Droplets of oil may come from the exhaust onto the deck as the oil is cleared from the cylinder. Simply wipe these away with an old rag.

**The correct way to tip your mower is BACKWARDS.**

**Engine Model: Honda GCV135  
and  
Honda GCV160**

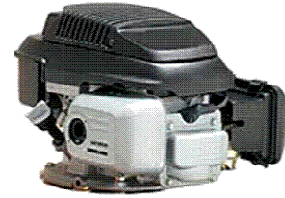

**C:** The engine pull cord may snatch back when pulled if the machine is not on a flat and firm surface, or the blade and/or its mounting boss are damaged or fitted insecurely.

1. Ensure the machine is situated on a firm level surface (path, patio or short grass). Check the underside of the machine is clear from old lawn debris. If you have to tilt the mower, do this backwards only. First remove the grass catcher, then lift the front wheels until the handles reach the ground at the rear.

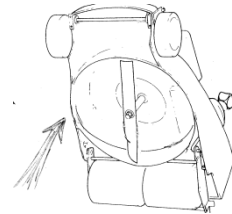

2. If attempting to start the mower on the lawn, the grass beneath the cutter can slow its rotation, and even prevent the free rotation of the cutter, causing a “snatch back”. If the engine is cold, select a firm surface for starting the mower. If the engine is warm, always pull the mower back onto a pre-mown area where the grass is already short to prevent unnecessary jamming.

**D:** To check the blade, pull the cap off the sparkplug (for safety) and remove the grass catcher from the rear of the mower. Tilt the mower **BACKWARDS** so that the handle touches the ground.

1. The cutter bar is retained by a central bolt. This should be tight (the thread is the normal anti-clockwise turn to tighten).

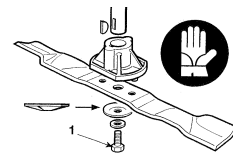

2. To either side of the central bolt there are two silver lugs protruding through the cutter bar. If these are missing, it indicates that the machine has come into contact with more than normal grass and has damaged the cutter mount (boss). This will have to be replaced. This type of repair would not normally be covered by warranty.

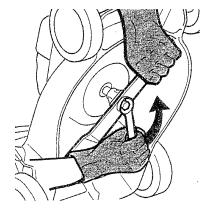

It is wise to mark the blade before removing it so that the blade can be replaced the correct way up.

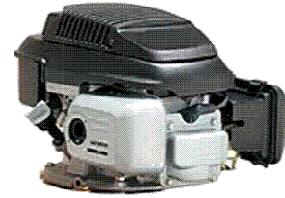

## 8 Cutting and Collecting Grass, Vibration

### QUICK TROUBLESHOOTING GUIDE:

<b>Problem:</b>	<b>Likely Cause:</b>	<b>Solution:</b>
<b>Mower will not cut grass properly</b>	<ul style="list-style-type: none"><li>• Technique is incorrect</li><li>• Grass is too long or wet</li><li>• Problem with the blade or blade mounting</li></ul>	<ul style="list-style-type: none"><li>• See A</li><li>• See A</li><li>• See B</li></ul>
<b>Mower vibrates excessively</b>	<ul style="list-style-type: none"><li>• Problem with the blade or blade mounting</li><li>• The engine mounting is loose</li></ul>	<ul style="list-style-type: none"><li>• See B</li><li>• See B</li></ul>
<b>Mower will not collect grass properly</b>	<ul style="list-style-type: none"><li>• Technique is incorrect</li><li>• Grass is too long or wet</li><li>• Build-up of grass clippings underneath or lack of air flow</li></ul>	<ul style="list-style-type: none"><li>• See A</li><li>• See A</li><li>• See C</li></ul>

### A MOWER WILL NOT CUT GRASS PROPERLY

**When cutting grass make sure you are using the machine on full throttle (if one is fitted).**

Especially in the Spring when the grass may be long and lush, do not attempt to cut too much grass at any one time.

If the lawn is several inches in length then raise the height of cut and gradually reduce the lawn in stages to prevent blocking. It may also help to remove the grass catcher, cut the grass first on the highest setting, and work down to lower settings and collecting the grass.

**Do not cut wet grass.**

If the grass is damp you can attempt to cut the lawn by raising the height of cut to allow a greater airflow, and reducing the lawn to the desired level in stages.

Check the height adjuster levers settings are the same on each wheel and that they are at a level suitable for the grass conditions.

#### **Mulching Mowers:**

The same advice above applies to mulching mowers. These are mowers that are not designed to collect grass. Instead they recycle the grass clippings, and grass becomes fertilizer for your lawn

To obtain the perfect cutting height you need to work down from the maximum height setting in steps until you reach your ideal height.

**Engine Model: Honda GCV135  
and  
Honda GCV160**

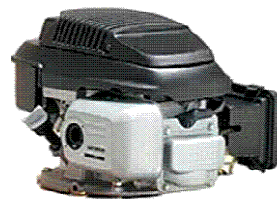

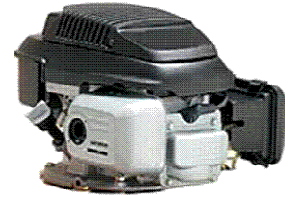

## B PROBLEMS WITH THE BLADE OR BLADE MOUNTING

Before checking the blade, REMOVE the H.T. lead (1 in the diagram). and ONLY TIP THE MOWER BACKWARDS.

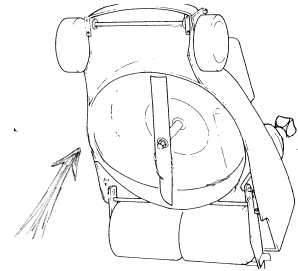
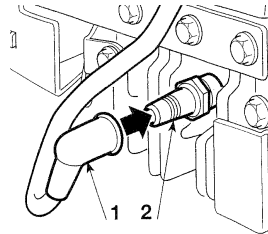

Excessive vibration can indicate damage to the blade, or blade mounting, or that the engine is loose

Check the blade bolt is tight.

*WARNING: Mark the blade before attempting to remove it. This will enable you to replace it the correct way up.*

Check the blade mount. The mount has two lugs one either side of the blade securing bolt. If these have sheered then the blade can move.

If the blade mount has failed, a replacement can be purchased through your local Mountfield dealer.

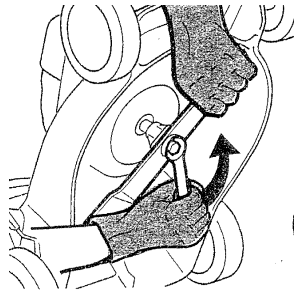

**Loosening the blade**  
(it is a normal thread, so turn anti-clockwise to remove the blade)

**The Blade mount is only likely to fail because the blade has come into contact with an obstruction of some form.** The blade mount is designed to fail in order to protect the engine crankshaft.

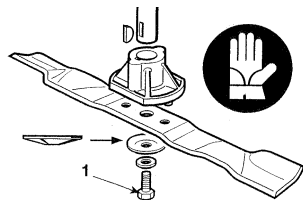

Check the condition of the cutter blade - if badly worn or damaged, replace with a new one. If a new cutter blade has been fitted, check that it has been installed the correct way up (the wing tips at either end should bend upward into the mower chassis and not downward towards the ground).

Check that all 3 bolts securing the engine are in place and tight.

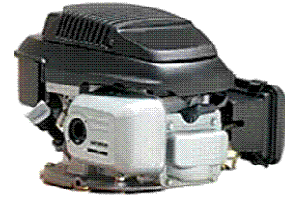

## C BUILD-UP OF GRASS CLIPPINGS UNDERNEATH or LACK OF AIRFLOW

**When cutting grass make sure you are using the machine on full throttle (if one is fitted).**

**Raising the height of cut increases airflow and assists grass collection. This is especially so if the grass is damp.**

**Reducing the height of cut in stages to achieve the desired level is a sound strategy.**

1. Ensure there is no build up of grass underneath the casing. **Before checking the underside, make sure to remove the HT Cap (sparkplug cap).** Only access the under side of the machine by removing the grass catcher then lifting the machine from the front until the handles touch the ground at the rear).
2. Check the grass catcher allows air to pass through it. If heavily soiled, wash it in warm soapy water to clear old deposits of grass juices and debris. A good airflow is essential for efficient grass collection.
3. If grass is very long, remove the grass catcher, and work with the deflector plate in position. Clippings can be collected after a few hours drying by simply going over the lawn again with the grass catcher fitted, and the wheels set slightly higher.
4. Should the machine become blocked with grass when using it, **stop the mower and remove the H.T. lead** (spark plug cap). Remove the grass box, insert your hand through the rear aperture and clean away any build up of grass clippings. **DO NOT TIP THE MOWER FORWARDS, OR SIDEWAYS, OR UPSIDE DOWN.**
5. Walk around to the front of the mower and raise the front wheels in the air until the handles reach the ground at the rear. Clean away any grass clippings which have accumulated on the underside.
6. Once cleaned, lower the machine, re-fit the HT lead (spark plug cap) and restart the engine.

**Engine Model: Honda GCV135  
and  
Honda GCV160**

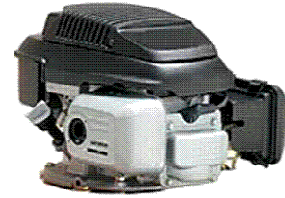

## 9 Transportation and Handling

The correct way to gain access underneath the mower:

Before checking the underside, make sure to remove the HT Cap (sparkplug cap).

**ALWAYS** lift from the front of the mower so that the front wheels are raised, and the handles touch the ground at the rear. Do not tip the mower sideways or forward (like one might lift a wheelbarrow) as this can flood the air filter, exhaust and even the cylinder with engine fluids.

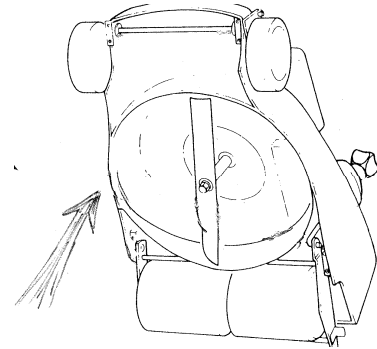

It may be helpful to place a weight on the handle to maintain the mower in this position when working beneath the deck.

**Whenever the machine is to be handled, raised onto a workbench or transported, remove the HT Cap (sparkplug cap):**

1. Wearing strong gloves and taking account of the weight and its distribution, grasp the machine at the points that offer a safe grip.
2. Use an appropriate number of people for the weight of the machine and the characteristics of the vehicle or the place where it has to be placed or collected.
3. When lifting the machine to and from a vehicle or onto a workbench, take care to keep it level. **DO NOT TIP IT.**
4. The handles may be folded to ease storage and transportation. It is important to take care not to trap the operating cables when collapsing the handles.

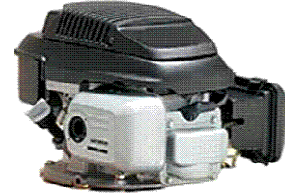

---

## **10 Maintenance and Storage**

**Regular and careful maintenance is essential to preserve original performance and safety levels of the engine. Always store the mower in a dry place. Please also refer to the Engine Routine Maintenance information for additional help.**

### **Key maintenance and storage information (all engines):**

- 1. Keep all nuts, bolts and screws tight** to ensure the equipment is in safe working condition. **Regular routine maintenance** is essential for safety and performance.
- 2. Never store the mower** with fuel in the tank inside a building where vapour may reach a flame or a spark or a source of extreme heat.
- 3. Allow the engine to cool** before storing in an enclosed space.
- 4. To reduce the fire hazard**, keep the engine, exhaust silencer, battery compartment (if fitted) and fuel storage area free of grass, leaves, or excessive grease. Do not leave containers of grass cuttings in rooms.
- 5. Check the stone guard and grass collector** frequently for wear and deterioration.
- 6. If the fuel tank has to be drained**, this should be done outside and when the engine is cool.
- 7. Wear strong work gloves** while removing or assembling the blade.
- 8. Keep the blade balanced during sharpening.** All operations on the blade (dismantling, sharpening, balancing, remounting and/or replacing) require a certain familiarity and (in some cases) special tools. For safety reasons these tasks are best carried out by one of our authorised service dealers.
- 9. For safety reasons, DO NOT use the equipment with worn or damaged parts.** Parts are to be replaced and not repaired. Use genuine spare parts only. Parts that are not of the same quality can damage the equipment and be dangerous for your safety.

**If the lawnmower is to be stored for more than 28 days (e.g. over the winter period), drain the fuel from the tank or allow the engine to run until it runs out of fuel. This should always be done outdoors. To empty the fuel from the engine, see section 4 Starting the engine, sub-section B.**

Alternatively, because this engine has a gravity feed, the engine can be allowed to run until it runs out of petrol.

For convenience during this process, the engine can be made to run on its own by simply securing the OPC lever against the handle and leaving the mower on a solid surface with the height of cut set to the lowest setting. ***Ensure there are no children or pets unsupervised nearby.***

**Engine Model: Honda GCV135  
and  
Honda GCV160**

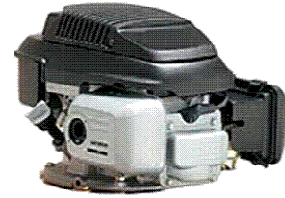

---

## 11 Guarantee, Spare Parts, Repairs

Congratulations on the purchase of your lawnmower. This product is guaranteed against faulty parts or manufacture for domestic use as shown below:

**MOWER MODEL:**

**GUARANTEE PERIOD:**

**422 HP, 462 PD, 512 PD  
SP535, Cooper 532PD**

**2 years from the date of purchase**

**SP555**

**2 years from the date of purchase on the engine  
and mower, and 10 years anti-corrosion  
warranty on the deck**

If the machine is used commercially the guarantee period is 90 days from the date of purchase.

If your product fails due to a defect in materials or workmanship during the guarantee period it will be repaired or replaced at no charge provided all repairs are carried out by an authorised service dealer. Delivery and collection of the machine is your responsibility, and not covered by this guarantee. To locate your nearest service dealer telephone the helpline on 0845 600 2912.

This guarantee is not transferable. Proof of purchase will be required in the event of a claim. Warranty is subject to the mower receiving annual service where there is a warranty for 2 or more years.

Normal wear-and-tear and the routine replacement of parts which are subject to normal wear-and-tear are not covered by this guarantee. Likewise, any defect which is the result of misuse, alteration, improper assembly or adjustment, neglect or accident is not covered by this guarantee.

This guarantee is in addition to, and does not detract from your original contractual rights under statute or common law.

### Spare Parts, Repairs

We do not supply spares parts direct for general use. We do, however, have a comprehensive Service Link network that can happily supply replacement parts for your mower. Our Service Link centres can also undertake any remedial work requested (work that is not covered by the guarantee will be chargeable). Your local Service Link can be found by contacting the Helpline and quoting the model of mower you have and your postcode. Alternatively, go to [www.servicelink.org.uk](http://www.servicelink.org.uk)

Our Helpline service, telephone 0845 600 2912 (Monday to Saturday 9am – 5pm, and Sunday 10am – 4pm).