

*Please Read These Instructions  
Before Using Your Mower*



# **Operating Instructions**

*for model  
481HP and 481PD Lawnmowers  
with Mountfield RV40 engine*



**Product Codes:  
294804048/TSC  
294805048/TSC**

*These instructions are an addition to and should be read in  
conjunction with the Operator Manual enclosed with this mower*

**Call our Helpline if you have any problems:-**

**0845 600 2912**

**Open from 9:00am to 5:00pm Monday to Saturday  
10.00am to 4.00pm on Sunday**

Thank you for purchasing a Cooper lawnmower. This machine will give you many years of safe and reliable service if operated in accordance with these instructions. **Please read and understand these Operating Instructions before using your mower, failure to do so could result in personal injury or damage to the equipment.**



**NEVER TIP THE MOWER ON ITS SIDE AS THIS WILL FLOOD THE AIR FILTER WITH OIL.**  
To access the underside, lift the front wheels by lowering the handle until it rests on the ground.

## SAFETY PRECAUTIONS

<b>Read these instructions before using your mower.</b>	<b>Keep hands and feet well away from the cutter blade.</b>	<b>Warning!</b>	<b>Remove the spark plug lead before working on the mower.</b>	<b>Beware of objects that may be thrown up by the blade.</b>	<b>Keep children, bystanders and pets away from the work area.</b>

The following safety precautions must be observed at all times. Please read them very carefully.

### GENERAL

- Know how to stop your mower quickly in an emergency. Understand all the controls and how they operate.
- Do not allow children or anyone who is unfamiliar with these instructions to use the mower. Local regulations may restrict the age of the operator.
- Keep children, pets and other bystanders well away from the work area.
- Never put your hands, feet or any implement under the cutter deck or inside the rear discharge chute. The cutter blade will continue to rotate for some time after the engine is switched off.

### STOP THE ENGINE AND DISCONNECT THE SPARK PLUG LEAD

- Before carrying out any adjustments, cleaning, inspection or maintenance.
- If your mower is damaged or vibrates excessively. Ensure the machine is in a safe working condition before it is restarted.
- Before clearing a blockage or unclogging the discharge chute.

### STOP THE ENGINE

- Whenever you leave the mower unattended.
- Before refilling with petrol or oil.

### PREPARATION

- Wear sturdy footwear and long trousers when using the mower. Never go barefoot or wear open sandals. Avoid loose clothing that may snag on moving parts.
- Check the work area and remove any stones or other debris that may be thrown up by, or cause damage to, the cutter blade.
- Before use ensure that the mower is in a safe working condition. Inspect the cutter blade for damage; check safety devices and guards; check that all nuts, bolts and screws are secure.
- Never use the machine without a silencer; or with a faulty silencer.

### FUEL SAFETY

#### **WARNING! – PETROL IS HIGHLY FLAMMABLE AND EXPLOSIVE UNDER CERTAIN CONDITIONS.**

- Store petrol in a cool place and only in containers specifically designed for the purpose.
- Refuel outdoors only, with the engine stopped. **DO NOT SMOKE** while refuelling.
- After refuelling, replace the fuel tank cap and the petrol container cap securely.
- Never remove the fuel tank cap, or add petrol, when the engine is hot or when it is still running.
- If any petrol is spilt do not attempt to start the engine. Move the mower away from the area, clean up the spillage and allow the fumes to dissipate before starting the engine.

### OPERATION

- Do not operate the engine in a confined space. Exhaust fumes contain CARBON MONOXIDE, an odourless and POISONOUS gas.
- Mow only in daylight or good artificial light.
- Check the oil and fuel levels before starting the engine.

- Disengage the engine brake and drive clutch before starting the engine.
- Start the engine in accordance with the instructions and with feet well away from the cutter blade.
- Do not tilt the mower when starting the engine.
- Do not change the engine settings. If adjustments are necessary, contact your dealer.
- The safety deflector flap must be in the down position if the mower is used without the grass collection bag in place.
- Operate the machine at a comfortable walking pace, never run behind the mower.
- Avoid operating the machine on wet grass whenever possible.
- Take care when working on slopes. Mow across the slope, never up and down, and exercise caution when changing direction. Do not use the mower on slopes of more than 20 degrees.
- Exercise extreme caution when reversing or pulling the mower towards you.
- Stop the cutter blade when emptying the grass collector, when crossing surfaces other than grass and when transporting the mower to and from the work area.
- Never pick up or carry the mower when the engine is running.

#### STORAGE & MAINTENANCE

- To reduce the risk of fire, keep the mower and petrol storage areas free of grass, leaves and grease.
- Check the mower and grass collector regularly to ensure the machine is in a safe working condition. Replace any worn or defective parts. Only use genuine replacement parts.
- Store the mower in a dry, secure place out of the reach of children and well away from any fire hazard.
- Allow the engine to cool before storage. If the fuel tank has to be drained, this should be done outdoors.

### KNOW YOUR MOWER



## HOW TO GET MOWING

Your Cooper lawnmower does not contain petrol or oil and these must be added before use. **Running the mower with insufficient oil can cause serious damage to the engine and will invalidate your warranty.**



**NEVER TIP THE MOWER ON ITS SIDE AS THIS WILL FLOOD THE AIR FILTER WITH OIL. To access the underside of the machine lift the front wheels by lowering the handle to the ground.**

Carefully remove the mower from the carton and read these Operating Instructions. An Owner's Manual for the engine is also included, please read this before starting the engine.

### HANDLE ASSEMBLY

- Raise the lower handle (1) to the upright position. Tighten the hand wheels and pivot bolts (2 and 3).
- Fit the upper handle (4) using the fittings supplied (5). Ensure that the bolt with the cord guide (6) is fitted correctly.
- Engage the Operator Presence Control (OPC) lever to release the engine brake. Pull the starter cord and fit it into the cord guide as shown.
- Use the cable ties (7) to fit the OPC cable (and clutch cable if fitted) to the handle assembly. .

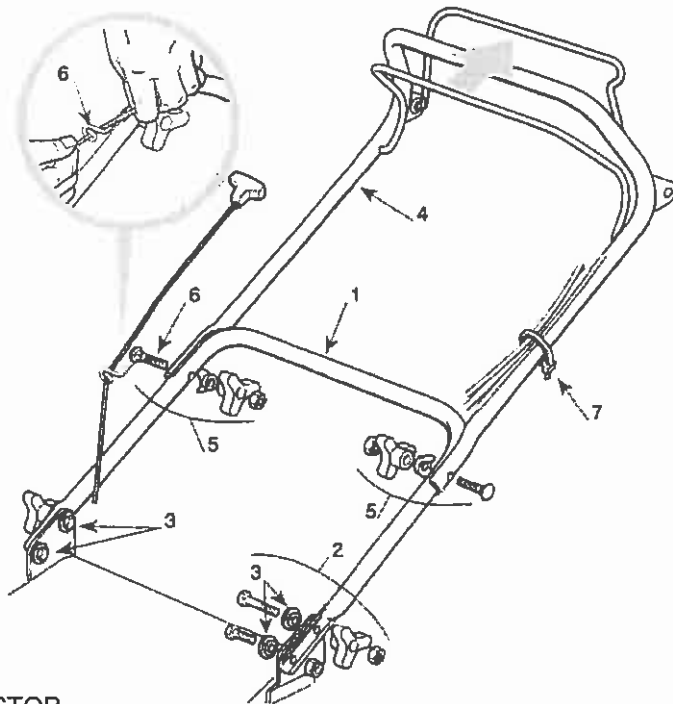

**Figure 1**

### GRASS COLLECTOR

- Remove the plate and washers from the top of the grass collector and clip the plate in place behind the handle.
- Turn the top upside down and fit the frame to it using screws and the washers which were on the plate.
- Fit the cloth base by fastening the plastic bars onto the frame, it may help to use a screwdriver as shown in the drawing to do this. Then click the edge into the groove in the top starting 5-7mm from an end (Figure2).
- To fit the grass collector onto the mower, lift the rear safety deflector flap and hook the collector onto the pegs.

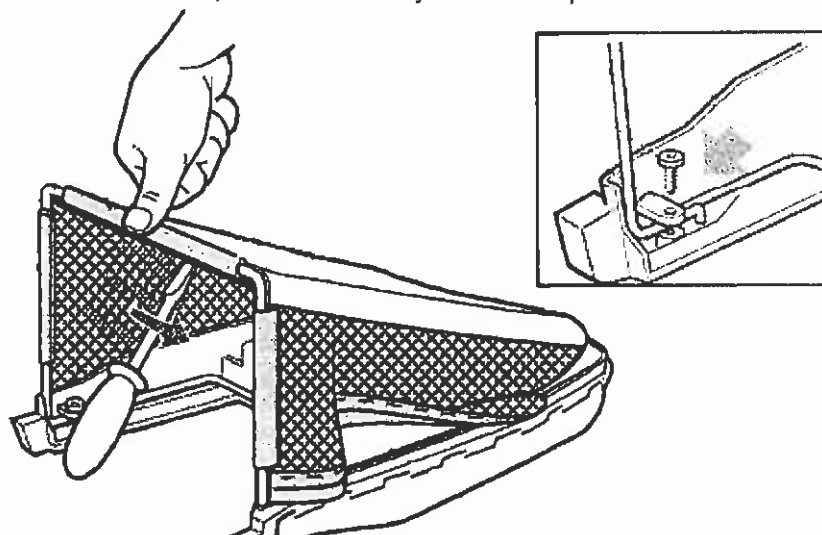
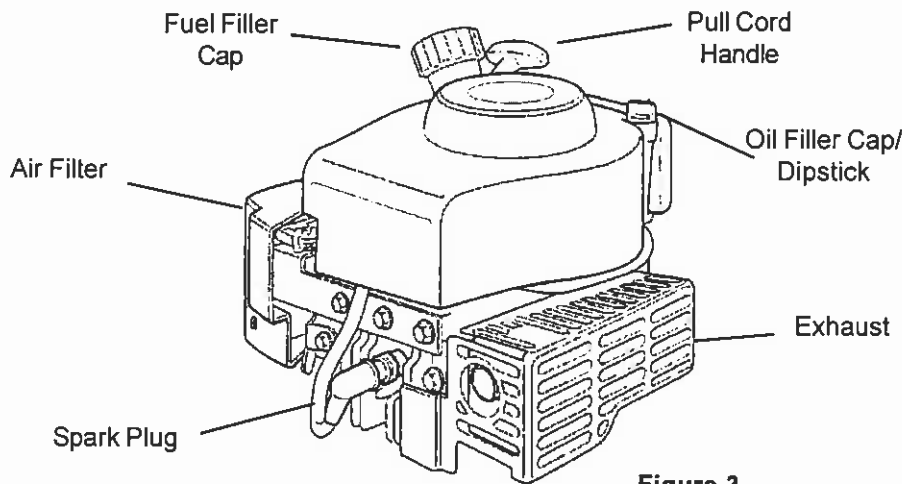

**Figure 2**

## STARTING YOUR MOWER

Read and understand the Safety Precautions before using your mower.

- Put Mountfield 4-stroke, or an SAE 10W-30 oil, in the oil filler (Figure 3). Do not overfill, the oil tank capacity is 0.6 litre. Mountfield oil, part number MX855, is available from any Mountfield stockist.
- Fill the fuel tank with UNLEADED petrol. Use only clean, fresh petrol - stale fuel may contain deposits that will clog the carburettor. Do not overfill, the petrol level should be below the bottom of the fuel tank neck..
- Ensure that the spark plug lead is securely connected to the spark plug.



**Figure 3**

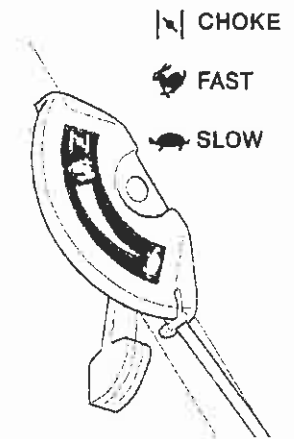

**Figure 4**

- Move the throttle control to the "Choke" position (Figure 4).
- Pull and hold the Operators Presence Control (OPC) lever against the handle to disengage the engine brake. **THE ENGINE WILL NOT START, OR CONTINUE TO RUN, UNLESS THE OPC LEVER IS HELD AGAINST THE HANDLE.**
- Pull the starter cord with a strong smooth pull. Do not remove the pull cord from the guide.
- When the engine starts move the throttle control from "Choke" to the "Fast" position.
- To engage the drive to the rear wheels on Power Driven models, pull and hold the clutch lever against the handle. To stop the drive, release the clutch lever.

*NOTE: Using the choke is usually unnecessary when starting a warm engine. However, in cool weather it may still be necessary to use the choke to start the engine.*

## STOPPING YOUR MOWER

- Release the Operators Presence Control (OPC) lever; this will engage the engine brake and operate the ignition safety cut out device.

## ADJUSTING THE HEIGHT OF CUT

The height of cut adjustment not only determines the length of the cut grass, it also controls the airflow which carries clippings into the collector. If the discharge chute becomes blocked, increase the airflow by raising the height of cut. To prevent blockages when cutting long, thick grass, set the adjustment to the highest setting and cut the grass; then cut it again on a lower setting.

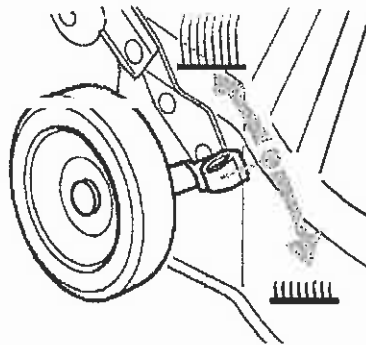

**Figure 5**

To adjust the height of cut:

- stop the engine and disconnect the spark plug.
- put the mower on a level surface.
- adjust the cutting height levers by pulling outwards and moving into the required position (Figure 5)
- check the cutter deck is level after adjusting the levers, i.e. that they are all set at the same height.

## BEFORE EACH USE

- Always ensure that the mower is in a safe working condition. Inspect the cutter blade for damage; check safety devices and guards; check that all nuts, bolts and screws are secure.
- Check the oil level as follows:
  - a) Remove the oil filler cap and wipe the dipstick clean (Figure 6).
  - b) Insert the dipstick into the filler neck and tighten down again. Remove the dipstick and check the oil level; oil should be at the MAX mark. The oil tank capacity is about 0.6 litre or 20 fluid oz.
  - c) If the oil level is low add Mountfield oil part number MX855 or a SAE 10W-30 oil, to the upper limit on the dipstick. Do not overfill; the oil level should not be above the MAX mark or below the MIN mark.
- Fill the fuel tank with unleaded petrol. Do not overfill; the level should be below the bottom of the fuel tank neck.

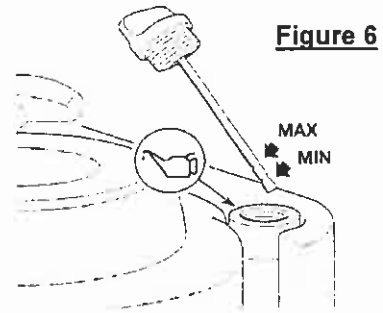

## MAINTENANCE



**Stop the engine and disconnect the spark plug lead before working on the machine. DO NOT TIP THE MOWER ONTO ITS SIDE AS THIS WILL FLOOD THE AIR FILTER WITH OIL. To access the underside of the machine, lift the front wheels by lowering the handle until it rests on the ground.**

### CUTTER BLADE

Examine the cutter blade regularly for wear or damage.

- A slightly worn blade can be re-sharpened by your local dealer.
- If the blade is damaged it should be replaced. Replacement blade kits are available from your Mountfield stockist. The part number for the blade kit is MS1196. If in doubt refer to your dealer, or telephone 0845 600 2912.

### CLUTCH CABLE ADJUSTMENT (Power Driven model only)

- Make sure that the clutch lever is fully released.
- Lengthen the cable adjuster by unscrewing it a couple of turns. (Figure 7)
- Engage the clutch lever and check that the rear wheels lock when the mower is pulled backwards.
- Start the mower and ensure it does not drive when the lever is disengaged.

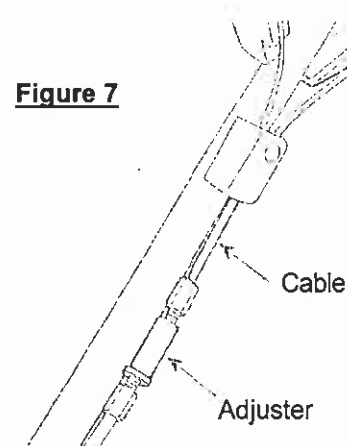

### ENGINE

An engine manufacturer's Owner's Manual is supplied with your mower. Please read this, it provides detailed information on engine operation and maintenance. Repair work other than routine maintenance, should be carried out by an authorised dealer.

### STORAGE

A little time spent on your mower after use will ensure many years of reliable mowing. To access the underside of the cutter deck, ensure the spark plug lead is disconnected, then lift the front wheels by lowering the handle until it rests on the ground. Do not tip the mower onto its side, as this will flood the air filter with oil.

### AFTER EACH USE

- Remove any grass pulp from the underside of the cutter deck using a non-metallic instrument such as a piece of wood. Take care not to damage the paintwork.
- Examine the cutter blade for any damage. A damaged blade may upset the balance of your mower and cause excessive vibration, if in doubt refer to your dealer.
- Inspect the grass collector and clean it if necessary. If the mesh becomes clogged airflow will be reduced and impair grass collection.
- The handle can be folded down to reduce the amount of storage space required. Take care not to trap any of the operating cables when folding or unfolding the handle.
- Store the mower in a clean, dry area well away from any naked flames, sparks or heat source.

### LONG TERM - If you are not using your mower for more than 28 days.

- Give the machine a thorough clean, paying particular attention to the underside.
- Lubricate all moving parts.
- At the end of the season, empty the fuel tank either by running the mower out of fuel or tip the machine backwards and onto the back right wheel to drain the fuel into a suitable container. Drain the carburettor by loosening the drain screw, retighten the drain screw.

## FAULT FINDING

PROBLEM	SOLUTION
Engine will not start	Check there is ample clean, fresh fuel in the tank.
	Check the cutter blade is not fouling the ground preventing free rotation.
Engine will not stop	Check the Operators Presence Control (OPC) lever is fully released.
	Remove spark plug lead to stop engine using insulated gloves and refer to dealer.
Failure to cut grass properly	Stop the engine and disconnect the spark plug lead using heat resistant gloves.
	Check blade attachment bolt is tight.
	Check condition of blade. If seriously worn or damaged replace with a new one.
Failure to collect grass properly	Stop the engine and disconnect the spark plug lead using heat resistant gloves.
	Check and make sure there is no build up of grass inside the casing.
	Check grass catcher is allowing air to flow through the fabric; if it is clogged it should be washed carefully.
	If the grass catcher is not clogged raise the height of cut to increase airflow.
	Check to ensure the engine is running at the correct speed, (approximately 3000rpm).
	If conditions are too severe to use the grass catcher, remove it and work with the deflector in position.
Machine vibrates excessively	This will certainly indicate that the blade has become badly damaged. Stop the engine, disconnect the spark plug lead and examine the blade assembly. Refer to your local dealer.

## CERTIFICATE OF CONFORMITY

A Certificate of Conformity similar to the one shown below is in a separate document enclosed with this mower.

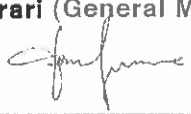
EC DECLARATION OF CONFORMITY	
The company .....	GGP ITALY SPA - Via del Lavoro, 6 31033 Castelfranco V.to (TV) ITALY
Certify that the lawnmower, walk behind with combustion engine .....	SP536 type ES 534 SP536ES type ESL 534 TR/E
Width of cut .....	51 cm
Engine .....	GGP - WBE 0701/ES
Tested by .....	SN 11 de luxemb -7 S NDV IL R
Conforms to the specification of directive .....	85/336/EEC ~ 2004/108/EC - 2000/14/EC
Conformity assessment procedure followed .....	ANNEX VI
Measured sound power level .....	96 dB(A)
Guaranteed sound power level .....	97 dB(A)
Reference to harmonised standards.....	EN 836 - EN 292-2- EN 1033 - EN ISO 3767 EN ISO 14982
Sound pressure level at the ear measured in compli- ance with 81/1051/EEC .....	81 dB(A)
Vibration level at the handle (EN 1033) .....	4 m/s <sup>2</sup>
Castelfranco Veneto (TV) - ITALY	01-10-2008
	S. Ferrari (General Manager) 

## Guarantee

GGP UK Limited undertakes to provide a full guarantee against defective materials or workmanship for two years from the date of purchase subject to the mower receiving an annual service.

If the machine is used for commercial purposes; i.e. for hire; or by contractors, caravan sites or similar users, this guarantee period shall be 90 days.

If any part or parts are found to be defective within the guarantee period, GGP UK Limited, via their authorised dealer, will effect the repair or replacement at no charge to the owner providing that the fault is reported direct to the dealer. All repairs must be carried out by an authorised Mountfield dealer. **Delivery and collection of the machine is the owner's responsibility and not covered under the terms of this guarantee.**

This guarantee is not transferable. Proof of purchase will be required in the event of a claim.

This guarantee does not apply to the routine replacement of parts that are subject to normal wear and tear – or to normal service and maintenance parts. This guarantee does not cover faults caused by neglect or misuse.





The engine manufacturer guarantees the engine fitted to this machine.

This guarantee is in addition to, and does not detract from, the contractual rights of the owner under statute or common law.

On delivery of your new Cooper mower, we suggest that you complete the box to the right.

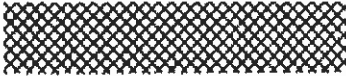
The information for your machine is on the serial number label, which is fixed on the cutter deck at the base of the handles. You will be asked for these details if you have any problems or require spare parts.

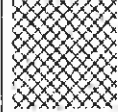
Please keep your receipt, proof of purchase will be required in the event of a claim.

	 LWA
Model: .....	 dB
Type: .....	
(Year) ..... S/N <sup>o</sup> .....	

## Service Record

### 1st Service

Date of Service: .....

Next Service Due: .....

Dealer's Signature: .....

Dealer's Stamp:

### 2nd Service

Date of Service: .....

Next Service Due: .....

Dealer's Signature: .....

Dealer's Stamp:

GGP UK LIMITED

Unit 8, Bluewater Estate, Bell Close, Plympton, Plymouth, Devon, PL7 4JH, England.